

[Click here to return to USGS publications](#)

# Theory of Aquifer Tests

---

U.S. GEOLOGICAL SURVEY WATER-SUPPLY PAPER 1536-E



# Theory of Aquifer Tests

*By* J. G. FERRIS, D. B. KNOWLES, R. H. BROWN, *and* R. W. STALLMAN

GROUND-WATER HYDRAULICS

---

GEOLOGICAL SURVEY WATER-SUPPLY PAPER 1536-E

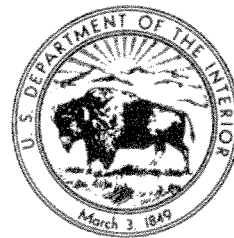

---

UNITED STATES GOVERNMENT PRINTING OFFICE, WASHINGTON : 1962

UNITED STATES DEPARTMENT OF THE INTERIOR  
MANUEL LUJAN, JR., Secretary

GEOLOGICAL SURVEY  
Dallas L. Peck, Director

Any use of trade, product, or firm names in this publication  
is for descriptive purposes only and does not imply  
endorsement by the U.S. Government

First Printing 1962  
Second printing 1963  
Third printing 1989

---

For sale by the Books and Open-File Reports Section, U.S. Geological Survey,  
Federal Center, Box 25425, Denver, CO 80225

## CONTENTS

---

	Page
Abstract.....	69
Introduction.....	69
Aquifer tests—the problem.....	70
Darcy's law.....	71
Coefficients of permeability and transmissibility.....	72
Coefficient of storage.....	74
The artesian case.....	75
The water-table case.....	76
Elasticity of artesian aquifers.....	78
Internal forces.....	78
Transmission of forces between aquifers.....	80
Effects of changes in loading.....	80
Excavations.....	80
Moving railroad trains.....	81
Changes in atmospheric pressure.....	83
Tidal fluctuations.....	85
Ocean, lake, or stream tides.....	85
Earth tides.....	86
Earthquakes.....	87
Coefficient of storage and its relation to elasticity.....	88
Aquifer tests—basic theory.....	91
Well methods—point sink or point source.....	91
Constant discharge or recharge without vertical leakage.....	91
Equilibrium formula.....	91
Nonequilibrium formula.....	92
Modified nonequilibrium formula.....	98
Theis recovery formula.....	100
Applicability of methods to artesian and water-table aquifers.....	102
Instantaneous discharge or recharge.....	103
"Bailer" method.....	103
"Slug" method.....	104
Constant head without vertical leakage.....	106
Constant discharge with vertical leakage.....	110
Leaky aquifer formula.....	110
Variable discharge without vertical leakage, by R. W. Stallman.....	118
Continuously varying discharge.....	118
Intermittent or cyclic discharge.....	122
Channel methods—line sink or line source.....	122
Constant discharge.....	122
Nonsteady state, no recharge.....	122
Constant head.....	126
Nonsteady state, no recharge, by R. W. Stallman.....	126
Steady state, uniform recharge.....	131
Sinusoidal head fluctuations.....	132



	Page
Aquifer tests—basic theory—Continued	
Areal methods	
Numerical analysis, by R. W. Stallman	135
Flow-net analysis, by R. R. Bennett	139
Theory of images and hydrologic boundary analysis	144
Perennial stream—line source at constant head	146
Impermeable barrier	147
Two impermeable barriers intersecting at right angles	151
Impermeable barrier and perennial stream intersecting at right angles	152
Two impermeable barriers intersecting at an angle of 45 degrees	154
Impermeable barrier parallel to a perennial stream	156
Two parallel impermeable barriers intersected at right angles by a third impermeable barrier	156
Rectangular aquifer bounded by two intersecting impermeable barriers parallel to perennial streams	159
Applicability of image theory involving infinite systems of image wells	159
Corollary equations for application of image theory	161
Applicability of analytical equations	166
References	168
Index	173

### ILLUSTRATIONS

	Page
FIGURE 17. Diagram for coefficients of permeability and transmissibility	72
18. Diagrams for coefficient of storage	77
19. Diagrams for elastic phenomena in artesian aquifers	79
20. Effect of excavating in confining material overlying artesian aquifer	81
21. Effects of changes in loading on artesian aquifer	82
22. Effect of atmospheric pressure loading on aquifers	83
23. Logarithmic graph of well function $W(u)$ —constant discharge	95
24. Relation of $W(u)$ and $u$ to $s$ and $r^2/t$	98
25. Equipment for a "slug" test	105
26. Logarithmic graph of well function $G(\alpha)$ —constant drawdown	108
27. Logarithmic graph of modified Bessel function $K_0(x)$	114
28. Nomenclature for continuously varying discharge	119
29. Family of curves for continuously varying discharge	121
30. Logarithmic graph of drain function $D(u)_c$ —constant discharge	124
31. Logarithmic graph of drain function $D(u)_h$ —constant head	128
32. Steady-state flow in aquifer uniformly recharged	130
33. Finite grid and nomenclature for numerical analysis	137
34. Flow net for discharging well in infinite-strip aquifer	142
35. Image-well analysis for discharging well near perennial stream	146
36. Flow net for discharging well near perennial stream	148
37. Image-well analysis for discharging well near impermeable boundary	149

## CONTENTS

v

	Page
FIGURE 38. Flow net for discharging well near impermeable boundary . . .	150
39. Image-well system for discharging well in quarter-infinite aquifer—two impermeable boundaries . . . . .	151
40. Image-well system for discharging well in quarter-infinite aquifer—one impermeable boundary . . . . .	153
41. Image-well system for discharging well in 45° wedge aquifer . . . . .	155
42. Image-well system for discharging well in infinite-strip aquifer . . . . .	157
43. Image-well system for discharging well in semi infinite-strip aquifer . . . . .	158
44. Image-well system for discharging well in rectangular aquifer . . . . .	160
45. Geometry for locating a point on a hydrologic boundary . . . . .	165

---

## TABLES

---

	Page
TABLE 1. Approximate average velocities and paths taken by different types of shock waves caused by earthquakes . . . . .	88
2. Values of $W(u)$ for values of $u$ between $10^{-15}$ and 9.9 . . . . .	96
3. Values of $G(\alpha)$ for values of $\alpha$ between $10^{-4}$ and $10^{12}$ . . . . .	109
4. Values of $K_0(x)$ , the modified Bessel function of the second kind of zero order, for values of $x$ between $10^{-2}$ and 9.9 . . . . .	115
5. Values of $D(u)$ , $u$ , and $u^2$ for channel method—constant discharge formula . . . . .	126
6. Values of $D(u)$ , $u$ , and $u^2$ for channel method—constant head formula . . . . .	127

## SYMBOLS

[The following symbols are listed in alphabetical order. Each symbol indicates the basic term usually represented, with no attempt to show the many and unavoidable duplicate uses. In the text, various subscripts are used in conjunction with these symbols to denote specific applications of the basic terms. A few of the more important combinations of this type are given; others are defined where they appear in the text.

- A* Area of cross section through which flow occurs.
- a* Distance from stream or drain to ground-water divide.
- e* Base of natural (Napierian) logarithms, numerically equal to 2.7182818.
- g* Local acceleration due to gravity.
- h* Head of water with respect to some reference datum.
- I* Hydraulic gradient.
- L* Length (width) of cross section through which flow occurs.
- m* Saturated thickness of an aquifer.
- m'* Saturated thickness of relatively impermeable bed confining an aquifer.
- P* Coefficient of permeability of the material comprising an aquifer.
- P'* Coefficient of vertical permeability of the material comprising a relatively impermeable bed that confines an aquifer.
- Q* Rate of discharge, or recharge.
- r* Radial distance from discharge or recharge well to point of observation.
- r<sub>w</sub>* Effective radius of discharge or recharge well.
- S* Coefficient of storage of an aquifer.
- s* Change in head of water, usually expressed as drawdown, or recovery or buildup.
- s'* Residual change in head of water, usually reserved for use in conjunction with the term, "drawdown".
- T* Coefficient of transmissibility of an aquifer.
- t* Elapsed time with respect to an initial reference.
- t'* Elapsed time with respect to a second reference.
- V* Volume.
- W* Rate of accretion or recharge to an aquifer.
- w* Spacing of grid lines used to subdivide a region into finite squares.
- z* Distance from stream or drain to point of observation.
- BE Barometric efficiency of an aquifer.
- TE Tidal efficiency of an aquifer.
- $D(u)_h$  Drain function of  $u$ , constant head situation.
- $D(u)_d$  Drain function of  $u$ , constant discharge situation.
- $G(\alpha)$  Well function of  $\alpha$ , constant head situation.
- $W(u)$  Well function of  $u$ , constant discharge situation.
- $J_0(x)$  Bessel function of first kind, zero order.
- $I_0(x)$  Modified Bessel function of first kind, zero order.
- $Y_0(x)$  Bessel function of second kind, zero order.
- $K_0(x)$  Modified Bessel function of second kind, zero order.
- $\alpha$  Bulk modulus of compression or vertical compressibility (reciprocal of the bulk modulus of elasticity) of the aquifer skeleton.

## CONTENTS

VII

- $\beta$  Bulk modulus of compression, or compressibility of water; approximate value for average ground-water temperature is  $3.3 \times 10^{-6}$  in  $^2/\text{lb}$ .
- $\gamma$  Specific weight of a substance.
- $\gamma_0$  Specific weight of water at a stated reference temperature; numerically equal to 62.4 lb per cubic foot at  $4^\circ\text{C}$  or  $39^\circ\text{F}$ .
- $\theta$  Porosity of an aquifer.
- $\rho$  Density of a substance.

# GROUND-WATER HYDRAULICS

---

## THEORY OF AQUIFER TESTS

---

By J. G. FERRIS, D. B. KNOWLES, R. H. BROWN, and R. W. STALLMAN

---

### ABSTRACT

The development of water supplies from wells was placed on a rational basis with Darcy's development of the law governing the movement of fluids through sands and with Dupuit's application of that law to the problem of radial flow toward a pumped well. As field experience increased, confidence in the applicability of quantitative methods was gained and interest in developing solutions for more complex hydrologic problems was stimulated. An important milestone was Theis' development in 1935 of a solution for the nonsteady flow of ground water, which enabled hydrologists for the first time to predict future changes in ground-water levels resulting from pumping or recharging of wells. In the quarter century since, quantitative ground-water hydrology has been enlarging so rapidly as to discourage the preparation of comprehensive textbooks.

This report surveys developments in fluid mechanics that apply to ground-water hydrology. It emphasizes concepts and principles, and the delineation of limits of applicability of mathematical models for analysis of flow systems in the field. It stresses the importance of the geologic variable and its role in governing the flow regimen.

The report discusses the origin, occurrence, and motion of underground water in relation to the development of terminology and analytic expressions for selected flow systems. It describes the underlying assumptions necessary for mathematical treatment of these flow systems, with particular reference to the way in which the assumptions limit the validity of the treatment.

### INTRODUCTION

Lectures on ground-water hydraulics by John G. Ferris provide most of the source material for this paper, which was organized by Doyle B. Knowles. Subsequent refinements of concepts and standardization of nomenclature and method of presentation were accomplished by Russell H. Brown and Robert W. Stallman, with the important collaboration of Edwin W. Reed. Appropriate individual authorship is recognized for several sections of the text.

The material presented herewith concerns the theory supporting many hydraulic concepts. Applications of the theory to field problems are to be shown in another report.

## AQUIFER TESTS—THE PROBLEM

The basic objective of ground-water studies of the U.S. Geological Survey is to evaluate the occurrence, availability, and quality of ground water. The science of ground-water hydrology is applied toward attaining that goal. Although many ground-water investigations are of a qualitative nature, quantitative studies are necessarily an integral component of the complete evaluation of occurrence and availability. The worth of an aquifer as a fully developed source of water depends largely on two inherent characteristics: its ability to store and its ability to transmit water. Furthermore, quantitative knowledge of these characteristics facilitates measurement of hydrologic entities such as recharge, leakage, and evapotranspiration. It is recognized that these two characteristics, referred to as the coefficients of storage and transmissibility, generally provide the very foundation on which quantitative studies are constructed. Within the science of ground-water hydrology, ground-water hydraulics methods are applied to determine these constants from field data.

Ground-water hydraulics, as now defined by common practice, can be described as the process of combining observed field data on water levels, water-level fluctuations, natural or artificial discharges, etc., with suitable equations or computing methods to find the hydraulic characteristics of the aquifer; it includes the logical extension of these data and computing methods to the prediction of water levels, to the design of well fields, the determination of optimum well yields, and other hydraulic uses—all under stated conditions. The selection of equations or computing procedures to be used for analysis is governed largely by the physical conditions of the aquifer studies, insofar as they establish the hydraulic boundaries of the system. The extraordinary variability in the coefficients of storage and transmissibility, combined with the irregularities in the shape of flow systems encountered in many ground-water studies, precludes uninhibited support of calculated coefficients based on vague or meager data. One quantitative test does not satisfy the demand for a quantitative study of an aquifer. It is merely a guidepost, indicator, or segment of knowledge, which must be supported by additional tests. Often the initially calculated results may require revision on the basis of the discoveries resulting from additional testing as the field investigation proceeds.

Obviously the results from ground-water hydraulics must be completely in accord with the geologic characteristics of the aquifer or of the area under investigation. Circumstance frequently demands that tests be conducted without prior knowledge of the geology in the vicinity of the test site. To varying degrees, lack of knowledge of the geology in most cases reduces the reliability of the test results to a semiquantitative category until more adequate support is found.

The principal method of ground-water hydraulics analysis is the application of equations derived for particular boundary conditions. The number of equations available has grown rapidly and steadily during the past few years. These are described in a wide assortment of publications, some of which are not conveniently available to many engaged in studies of ground-water hydraulics. The essence of each of many concepts of hydraulics is presented and briefly discussed, but frequent recourse should be made to the more exhaustive treatment given in the cited reference.

Where the definition of a hydraulics or ground-water term is considered necessary, it is stated where the term first appears, and the symbol and units in which the term is ordinarily expressed are given. Much of the terminology is assembled under "Symbols," following the table of contents.

#### DARCY'S LAW

Hagen (1839) and Poiseuille (1846) were the first to study the law of flow of water through capillary tubes. They found that the rate of flow is proportional to the hydraulic gradient. Later Darcy (1856) verified this observation and demonstrated its applicability to the laminar (viscous, streamline) flow of water through porous material while he was investigating the flow of water through horizontal filter beds discharging at atmospheric pressure. He observed that, at low rates of flow, the velocity varied directly with the loss of head per unit length of sand column through which the flow occurred and expressed this law as

$$v = \frac{Ph}{l}$$

in which  $v$  is velocity of the water through a column of permeable material,  $h$  is the difference in head at the ends of the column,  $l$  is the length of the column, and  $P$  is a constant that depends on the character of the material, especially the size and arrangement of the grains.

The velocity component in laminar flow is proportional to the first power of the hydraulic gradient. It can be seen, therefore, that Darcy's law is valid only for laminar flow. The flow is probably turbulent or in a transitional stage from laminar to turbulent flow near the screens of many large-capacity wells. Jacob (1950) agrees with Meinzer and Fishel (1934) that because water behaves as a viscous fluid at extremely low hydraulic gradients, it will obey Darcy's law at gradients much smaller than can be measured in the laboratory. He points out, however, that Darcy's law may not be valid for the flow of water in sands that are not completely saturated, or in extremely fine grained materials.

### COEFFICIENTS OF PERMEABILITY AND TRANSMISSIBILITY

The *coefficient of permeability*,  $P$ , of material comprising a formation is a measure of the material's capacity to transmit water. The coefficient of permeability was expressed by Meinzer (Stearns, N.D., 1928) as the rate of flow of water in gallons per day through a cross-sectional area of 1 square foot under a hydraulic gradient of 1 foot per foot at a temperature of 60°F. In figure 17, then, it would be the flow of water through opening A, which is 1 foot square. In field practice the adjustment to the standard temperature of 60°F. is commonly ignored and permeability is then understood to be a field coefficient at the prevailing water temperature. Theis (1935) introduced the term *coefficient of transmissibility*,  $T$ , which is expressed

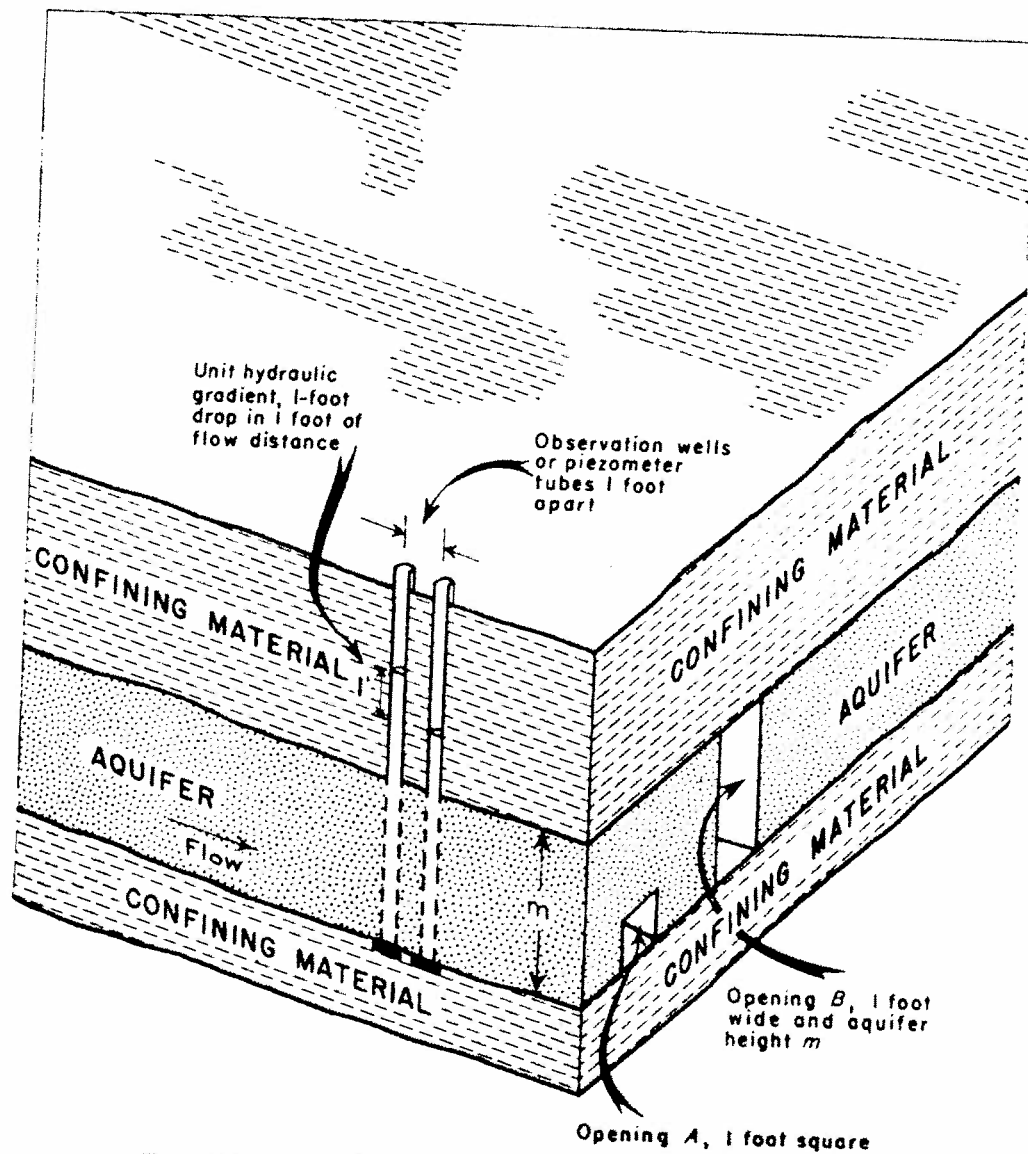

FIGURE 17.—Diagram for coefficients of permeability and transmissibility.



as the rate of flow of water, at the prevailing water temperature, in gallons per day, through a vertical strip of the aquifer 1 foot wide extending the full saturated height of the aquifer under a hydraulic gradient of 100 percent. In figure 17 it would be the flow through opening B, which has a width of 1 foot and a height equal to the thickness,  $m$ , of the aquifer. A hydraulic gradient of 100 percent means a 1-foot drop in head in 1 foot of flow distance as shown schematically by the pair of observation wells in figure 17. It is seldom necessary to adjust the coefficient of transmissibility to an equivalent value for the standard temperature of 60°F., because the temperature range (and, hence, range in viscosity) in most aquifers is not large. The relation between the coefficient of transmissibility and the field coefficient of permeability, as they apply to flow in an aquifer, can be seen in figure 17.

A useful form of Darcy's law, which is often applied in studies of ground-water hydraulics problems, is given by the expression

$$Q_a = PIA$$

in which  $Q_a$  is the discharge, in gallons per day;  $P$  is the coefficient of permeability, in gallons per day per square foot;  $I$  is the hydraulic gradient, in feet per foot; and  $A$  is the cross-sectional area, in square feet, through which the discharge occurs. For most ground-water problems, this expression can be more conveniently written as

$$Q_a = TIL$$

in which  $Q_a$  and  $I$  are defined as above,  $T$  is the coefficient of transmissibility in gallons per day per foot, and  $L$  is the width, in feet, of the cross section through which the discharge occurs. In many field problems it may be more practical to express  $I$  in feet per mile and  $L$  in miles. The units for  $T$  and  $Q_a$  will remain as already stated. The coefficient of transmissibility may be determined by means of field observations of the effects of wells or surface-water systems on ground-water levels. It is then possible to determine the field coefficient of permeability from the formula  $P = T/m$ . Physically, however,  $P$  has limited significance under these conditions. It merely represents the overall average permeability of an ideal aquifer that behaves hydraulically like the aquifer tested.

In general, laboratory measurements of permeability should be applied with extreme caution. The packing arrangement of a poorly sorted sediment is a critical factor in determining the permeability, and large variations in permeability may be introduced by repacking a disturbed sample. Furthermore, a laboratory measurement of permeability on one sample is representative of only a minute part of the water-bearing formation. Obviously, therefore, if quantitative data

are to be developed by laboratory methods, it is desirable to collect samples of the water-bearing material at close intervals of depth and at as many locations within the aquifer as is feasible.

#### COEFFICIENT OF STORAGE

The *coefficient of storage*,  $S$ , of an aquifer is defined as the volume of water it releases from or takes into storage per unit surface area of the aquifer per unit change in the component of head normal to that surface.

A simple way of visualizing this concept is to imagine an artesian aquifer which is elastic and uniform in thickness, and which is assumed, for convenience, to be horizontal. If the head of water in that aquifer is decreased, there will be released from storage some finite volume of water that is proportional to the change in head. Because the aquifer is horizontal, the full observed head change is evidently effective perpendicular to the aquifer surface. Imagine further a representative prism extending vertically from the top to the bottom of this aquifer, and extending laterally so that its cross-sectional area is coextensive with the aquifer-surface area over which the head change occurs. The volume of water released from storage in that prism, divided by the product of the prism's cross-sectional area and the change in head, results in a dimensionless number which is the coefficient of storage. If this example were revised slightly, it could be used to demonstrate the same concept of coefficient of storage for a horizontal water-table aquifer or for a situation in which the head of water in the aquifer is increased.

As with almost any concise definition of a basic concept it is necessary to develop its full significance, its limitations, and its practical use and application through elaborative discussion. The coefficient of storage is no exception in this respect, and the following discussion will serve to bring out a few ideas that are important in applying the concept to artesian and water-table aquifers in horizontal or inclined attitudes.

Observe that the statement of the storage-coefficient concept first focuses attention on the volume of water that the aquifer releases from or takes into storage. Identification and measurement of this volume poses no particular problem, but it should be recognized that it is measured outside the aquifer under the natural local conditions of temperature and atmospheric pressure; it is not the volume that the same amount of water would occupy if viewed in place in the aquifer.

Although the example used to depict the concept of the storage coefficient was arbitrarily developed around a horizontally disposed artesian aquifer, the concept applies equally well to water-table aquifer-

fers and is not compromised by the attitude of the aquifer. This flexibility of application relies importantly, however, on relating the storage-coefficient concept to the surface area of the aquifer and to the component of head change that is normal to that surface. In turn this relation presupposes that the particular aquifer prism involved in the movement of water into or out of storage is that prism whose length equals the saturated thickness of the aquifer, measured normal to the aquifer surface, and whose cross-sectional area equals the area of the aquifer surface over which the head change occurs. Furthermore, water moves into or out of storage in this prism in direct proportion only to that part of the head change that acts to compress or distend the length of the prism. In other words, the component of the head change to be considered in the release or storage of water is that which acts normal to the aquifer surface. The mathematical models devised for analyzing ground-water flow usually require uniform thickness of aquifer. However, the storage coefficient concept, as defined here, applies equally well to aquifers that thicken or thin substantially, if the "surface area" is measured in the plane that divides the aquifer into upper and lower halves that are symmetrical with respect to flow. The imaginary prism would then be taken perpendicular to this mean plane of flow.

#### THE ARTESIAN CASE

Consider an artesian aquifer, in any given attitude, in which the head of water is changed, but which remains saturated before, during, and after the change. It is assumed that the beds of impermeable material confining the aquifer are fluid in the sense that they have no inherent ability to absorb or dissipate changes in forces external to or within the aquifer. Inasmuch as no dewatering or filling of the aquifer is involved, the water released from or taken into storage can be attributed only to the compressibility of the aquifer material and of the water. By definition the term "head of water" and any changes therein connote measurements in a vertical direction with reference to some datum. In a practical field problem the change in head very likely would be observed as a change in water-level elevation in a well. The change in head is an indication of the change in pressure in the aquifer prism, and the total change in force tending to compress the prism is equal to the product of the change in pressure multiplied by the end area of the prism. Obviously this change in force is not affected by the inclination of the aquifer, inasmuch as a confined pressure system is involved and the component of force due to pressure always acts normal to the confining surface. Thus any conventional method of observing head change will correctly identify the change in pressure normal to the aquifer surface and may be considered as a component of head acting normal to that surface.

Examine figure 18A, which depicts, in schematic fashion, a horizontal artesian aquifer. Shown within the aquifer is a prism of unit cross-sectional area and of height,  $m$ , equal to the aquifer thickness. If the piezometric surface is lowered a unit distance,  $z$ , as shown, a certain amount of water will be released from the aquifer prism. This occurs in response to a slight expansion of the water itself and a slight decrease in porosity due to distortion of the grains of material composing the aquifer skeleton.

*Summary statement.*—For an artesian aquifer, regardless of its attitude, the water released from or taken into storage, in response to a change in head, is attributed solely to compressibility of the aquifer material and of the water. The volume of water (measured outside the aquifer) thus released or stored, divided by the product of the head change and the area of aquifer surface over which it is effective, correctly determines the storage coefficient of the aquifer. Although rigid limits cannot be established, the storage coefficients of artesian aquifers may range from about 0.00001 to 0.001.

#### THE WATER-TABLE CASE

Application of the storage coefficient concept to water-table aquifers is more complex, though reasoning similar to that developed in the preceding paragraphs can be applied to the saturated zone of an inclined water-table aquifer. Consider a water-table aquifer, in any given attitude, in which the head of water is changed. Obviously there will now be dewatering or refilling of the aquifer, inasmuch as it is an open gravity system with no confinement of its upper surface. Thus the volume of water released from or taken into storage must now be attributed not only to the compressibility of the aquifer material and of the water, in the saturated zone of the aquifer, but also to gravity drainage or refilling in the zone through which the water table moves. The volume of water involved in the gravity drainage or refilling, divided by the volume of the zone through which the water table moves, is the specific yield. Except in aquifers of low porosity the volume of water involved in gravity drainage or refilling will ordinarily be so many hundreds or thousands of times greater than the volume attributable to compressibility that for practical purposes it can be said that the coefficient of storage equals the specific yield. The conventional method of measuring change in head by observing change in water-level *elevation* in a well evidently identifies the *vertical* change in position of the water table. In other words, head change equals vertical movement of the water table. It can be seen that the volume of the zone through which the water table moves is equal to the area of aquifer surface over which the head change occurs, multiplied by the head change, multiplied by the cosine

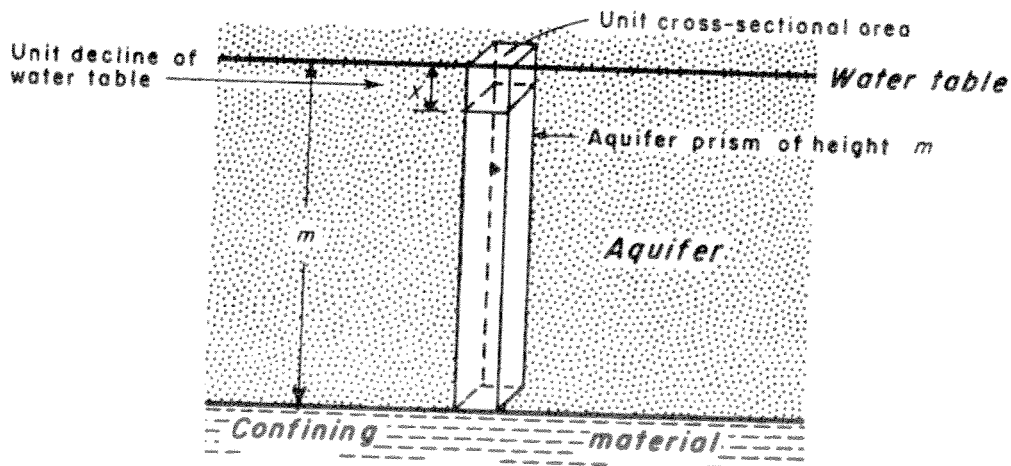
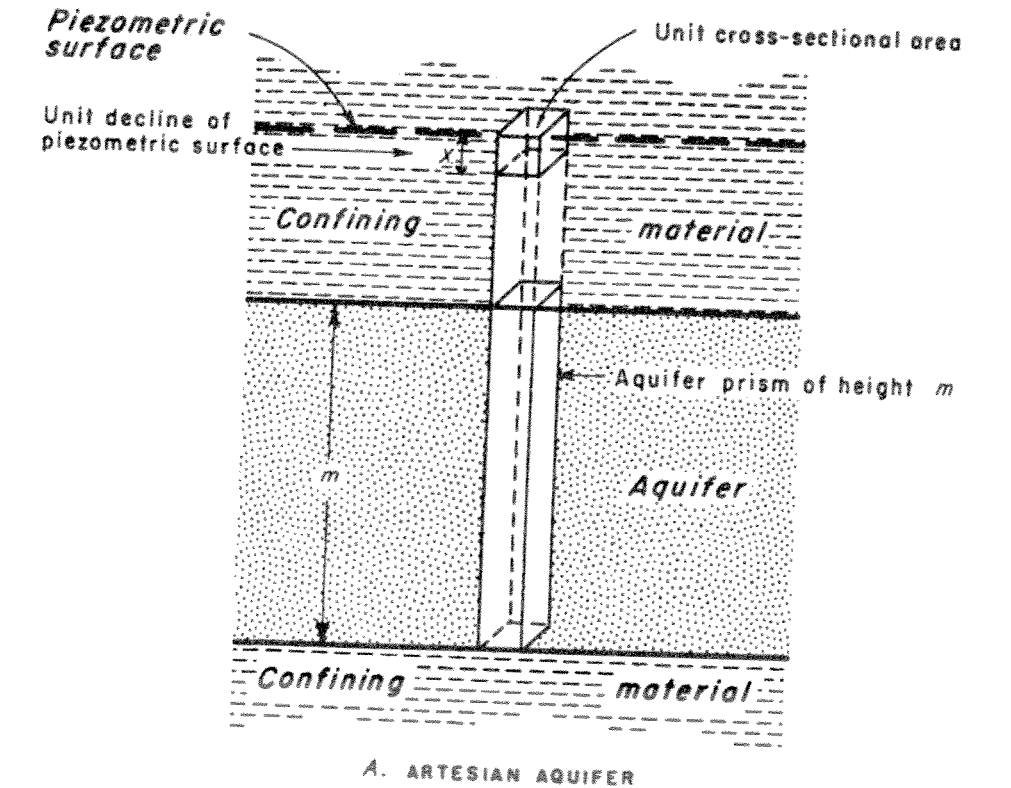

FIGURE 18.—Diagrams for coefficient of storage.

of the angle of inclination of the water table. The product of the last two factors is the component of head change acting normal to the aquifer surface. The importance of interpreting correctly the phrase "component of head change" which appears in the definition of the storage coefficient cannot be overemphasized.

Examine figure 18B, which depicts, in schematic fashion, a horizontal



water-table aquifer. Again a unit prism of the aquifer is shown, and it is assumed that the water table is lowered a unit distance,  $z$ . Usually the water that is thereby released represents, for practical purposes, the gravity drainage from the  $z$  portion of the aquifer prism. Theoretically, however, a slight amount of water comes from the portion of the prism that remains saturated, in accord with the principles discussed for the artesian case.

*Summary statement.*—For a water-table aquifer, regardless of its attitude, the water released from or taken into storage, in response to a change in head, is attributed partly to gravity drainage or re-filling of the zone through which the water table moves, and partly to compressibility of the water and aquifer material in the saturated zone. The volume of water thus released or stored, divided by the product of the area of aquifer surface over which the head change occurs and the component of head change normal to that surface, correctly determines the storage coefficient of the aquifer. Usually the volume of water attributable to compressibility is a negligible proportion of the total volume of water released or stored and can be ignored. The storage coefficient then is sensibly equal to the specific yield. The storage coefficients of water-table aquifers range from about 0.05 to 0.30.

#### ELASTICITY OF ARTESIAN AQUIFERS

It has long been recognized that artesian aquifers have volume elasticity. D. G. Thompson, though not the first to publish on the subject, apparently was among the first in the Geological Survey to recognize this phenomenon. In studying the relation between the decline in artesian head and the withdrawals of water from the Dakota sandstone in North Dakota, Meinzer (Meinzer and Hard, 1925) came to the conclusion that the water was derived locally from storage. He found that the withdrawals could not be accounted for by the compressibility of the water alone, but might be accounted for by the compressibility of the aquifer.

#### INTERNAL FORCES

The diagram in figure 19A shows the forces acting at the interface between an artesian aquifer and the confining material. These forces may be expressed algebraically as

$$s_t = s_w + s_s$$

where  $s_t$  is the total load exerted on a unit area of the aquifer,  $s_w$  is that part of the total load borne by the confined water, and  $s_s$  is that part borne by the structural skeleton of the aquifer. Assume that the total load ( $s_t$ ) exerted on the aquifer is constant. If  $s_w$  is reduced,

as a result of pumping, the load borne by the skeleton of the aquifer increases and there is slight distortion of the component grains of material. At the same time, the water expands to the extent permitted by its elasticity. Distortion of the grains of the aquifer skeleton means that they will encroach somewhat on pore space formerly occupied by water.

Conversely, if  $s_w$  is increased, as in response to cessation of pumping, the piezometric head builds up again gradually approaching its original value, and the water itself undergoes slight contraction. With an increase in  $s_w$  there is an accompanying decrease in  $s_s$  and the grains of material in the aquifer skeleton return to their former

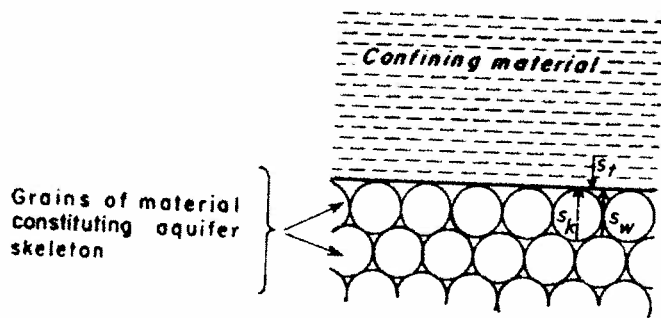

A MICROSCOPIC VIEW OF FORCES ACTING AT INTERFACE BETWEEN ARTESIAN AQUIFER AND CONFINING MATERIAL

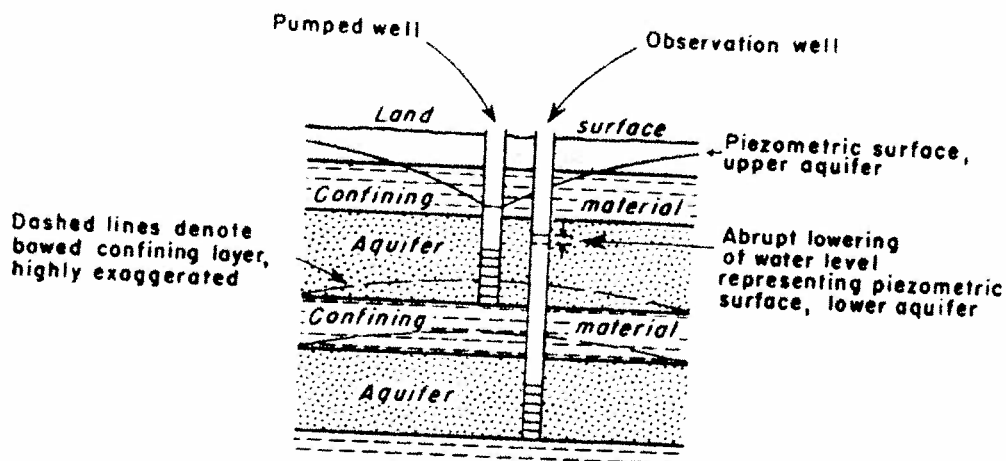

B. DIAGRAM SHOWING THE EFFECT ON A DEEP ARTESIAN AQUIFER OF PUMPING FROM A SHALLOW ARTESIAN AQUIFER

FIGURE 19.—Diagrams for elastic phenomena in artesian aquifers.

shape. This releases pore space that can now be reoccupied by water moving into the part of the formation that was influenced by the compression.

#### TRANSMISSION OF FORCES BETWEEN AQUIFERS

It has been observed in some places that a well pumping from an aquifer affects the water level in a nearby well that is screened in a deeper or shallower artesian aquifer. Consider the case shown in figure 19B. The well screened in the upper aquifer, for convenience depicted as artesian, is pumped and the water level in the well screened in the lower aquifer abruptly declines when pumping begins. As pumping continues, the water level of the lower aquifer ceases to decline and gradually recovers its initial position. Although not proved, a logical explanation of this phenomenon may be as follows: When the well in the upper aquifer begins pumping, there is a lowering of the pressure head in the vicinity of the pumped well. The decrease in pressure head unbalances the external forces that were acting on the upper and lower surfaces of the confining layer separating the two aquifers. In seeking a new static balance the confining layer will be bowed upward slightly thereby creating additional water storage space in the lower aquifer. The abrupt lowering of water level in the observation well represents the response to the newly created storage space and the reduction in the forces  $s_z$  and  $s_w$  in the lower aquifer. The subsequent water-level recovery, approaching the initial position, represents filling of the new storage space and return to the original pressure head as water in the lower aquifer moves in from more remote regions.

An interesting phenomenon that has been observed a few times, but for which no completely satisfactory explanation has yet been given, is that where pumping a well in one artesian aquifer causes a rise in the water level in a nearby well producing from a different artesian aquifer. (See Barksdale, Sundstrom, and Brunstein, 1936; and Andreasen and Brookhart, 1952.)

#### EFFECTS OF CHANGES IN LOADING

##### EXCAVATIONS

"Blowthroughs" may occur if deep excavations are made in the confining materials overlying an artesian aquifer that has a high artesian head. This is shown diagrammatically in figure 20. An excavation lowers the total load on part of the aquifer, which means that the forces  $s_w$  and  $s_z$  (see fig. 19A), are now the dominant forces acting on the remaining layer of confining material, separating the bottom of the excavation from the top of the aquifer. Thus this layer will be bowed upward and if it is incompetent to contain the



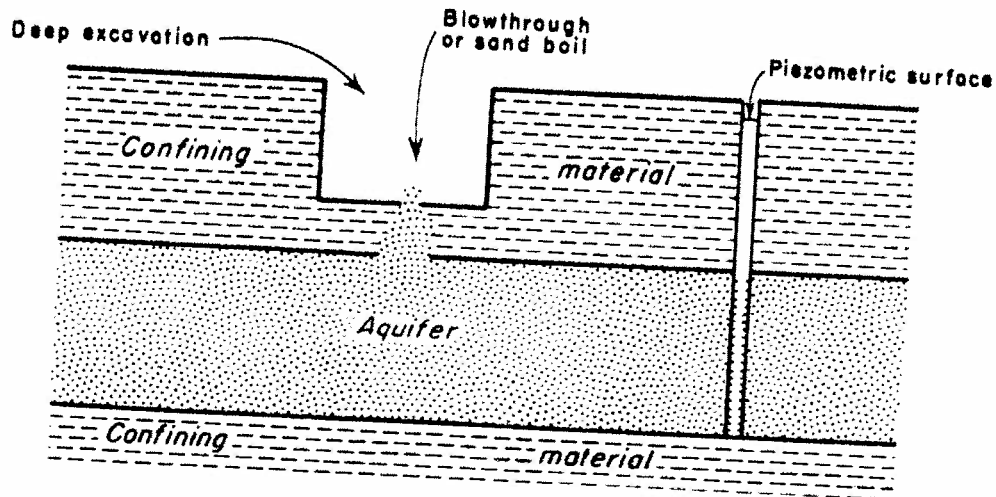

FIGURE 20.—Excavating in material overlying artesian aquifers.

bowing forces, it will rupture in the form of “blowthroughs” or “sand boils.” It is the practice in Holland (Krul and Lieftrinck, 1946), where this situation is commonly encountered, to install relief wells to lower the artesian head until an excavation is refilled.

#### MOVING RAILROAD TRAINS

It is a frequent observation that a passing railroad train affects the water levels in nearby artesian wells. This is another demonstration of the elasticity of artesian aquifers. The fluctuation of water level in a well on Long Island, N. Y., produced by a passing railroad train is shown in figure 21A. As the train approaches the well, an additional load is placed on the aquifer. This load tends to compress the aquifer, causing a rapid rise in water level that reaches a maximum when, or shortly after, the locomotive is opposite the well. As the aquifer becomes adjusted to the new loading, the water level declines toward its initial position. When the entire train has passed the well, the aquifer expands and the water level in the well declines rapidly and reaches a minimum shortly after the train has left the well. The water level then recovers toward its initial position as the aquifer again becomes adjusted to this new condition of loading. The time required for this cycle of events is commonly a few minutes. Thus the fluctuations in water levels caused by the passing of a train usually appear as vertical lines on water-stage recorder charts because the time scale ordinarily used is too small to record the fluctuations in any greater detail.

The diagram in figure 21B shows, schematically, the effect of an instantaneously applied load on the pressure distribution within an elastic artesian aquifer and on the compression and subsequent ex-

## GROUND-WATER HYDRAULICS

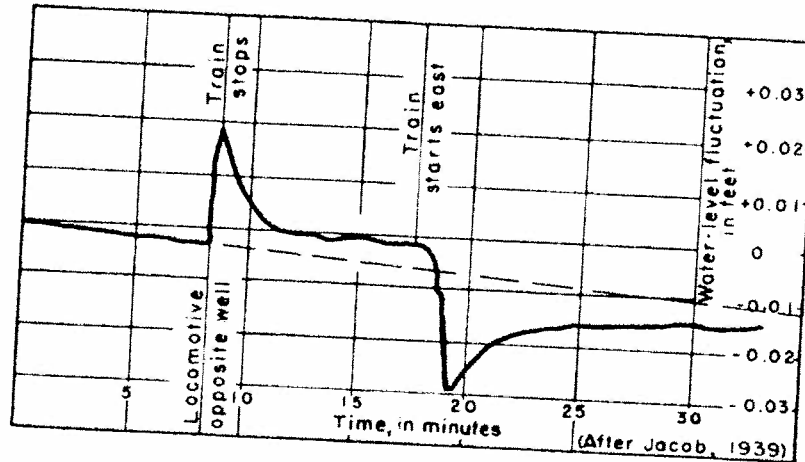

A. WATER-LEVEL FLUCTUATION IN WELL S-201, LONG ISLAND, N.Y., PRODUCED BY EAST-BOUND FREIGHT TRAIN, MARCH 21, 1938

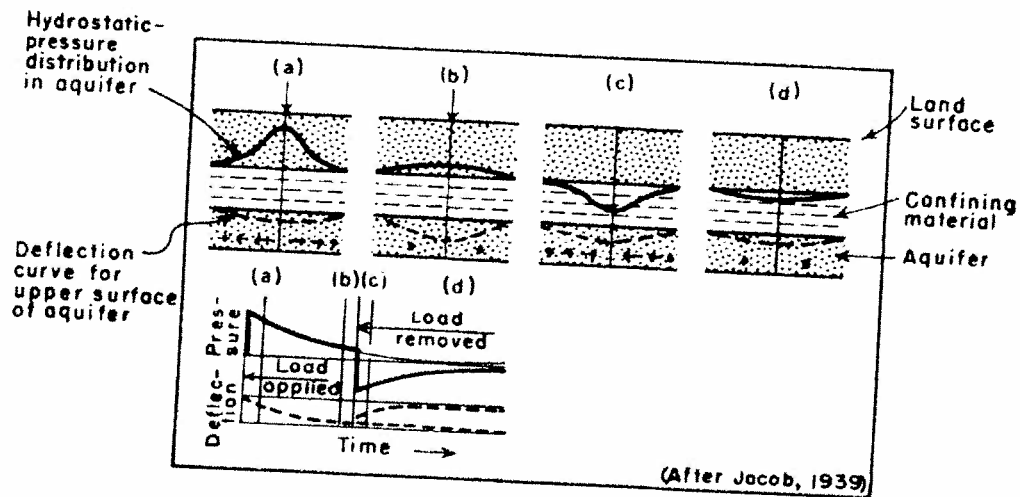

B. SCHEMATIC DIAGRAM SHOWING EFFECT OF INSTANTANEOUS APPLICATION AND SUBSEQUENT REMOVAL OF A SINGLE CONCENTRATED LOAD AT THE LAND SURFACE ON THE PRESSURE DISTRIBUTION AND ON THE COMPRESSION AND SUBSEQUENT EXPANSION OF AN ELASTIC ARTESIAN AQUIFER

FIGURE 21.—Effects of changes in loading on artesian aquifer.

pansion of the aquifer after removal of the load. In discussing figure 21B Jacob (1939) says:

The upper diagrams a, b, c, and d show the distribution of pressure and the deflection of the upper surface of the aquifer at the respective times indicated on the time-pressure and time-distribution curves. The hydrostatic pressure in the aquifer is plotted as a full line, the upper limit of the confining layer arbitrarily being adopted as a base. The deflection curve for the upper surface of the aquifer is plotted as a dashed line. (The lower surface of the aquifer is assumed fixed.) These quantities are, of course, grossly exaggerated and are obviously plotted to quite different scales. The length of the arrows indicates the relative magnitude of the velocity of flow at various distances from the load. The lower diagram . . . shows, by the heavy full line, the change in pressure produced by the load, and, by the heavy dashed line, the deflection of the upper surface of the aquifer, plotted against time.

CHANGES IN ATMOSPHERIC PRESSURE

It has often been observed that water levels in wells tapping artesian aquifers respond to changes in atmospheric pressure. An increase in the atmospheric pressure causes the water level to decline, and a decrease in atmospheric pressure causes the water level to rise. The diagrams shown in figure 22 will aid in explaining why this phenomenon is observed in artesian wells and why it ordinarily is not observed in water-table wells.

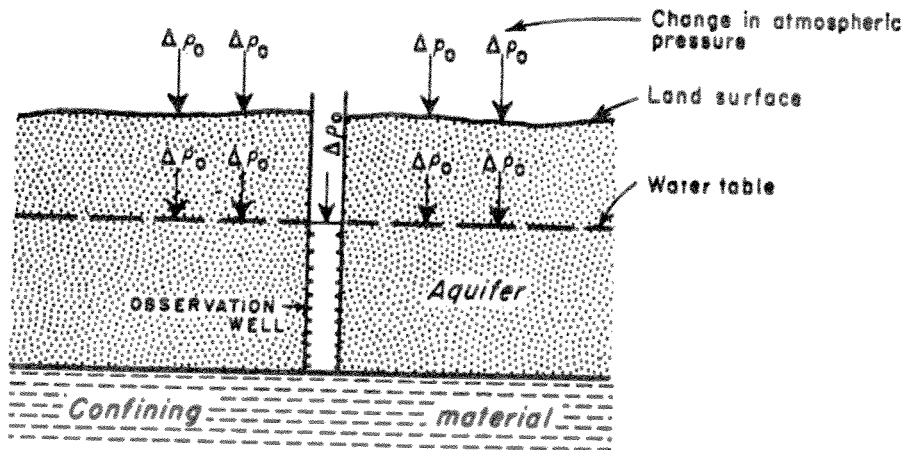

A. IDEALIZED SECTION OF WATER-TABLE AQUIFER

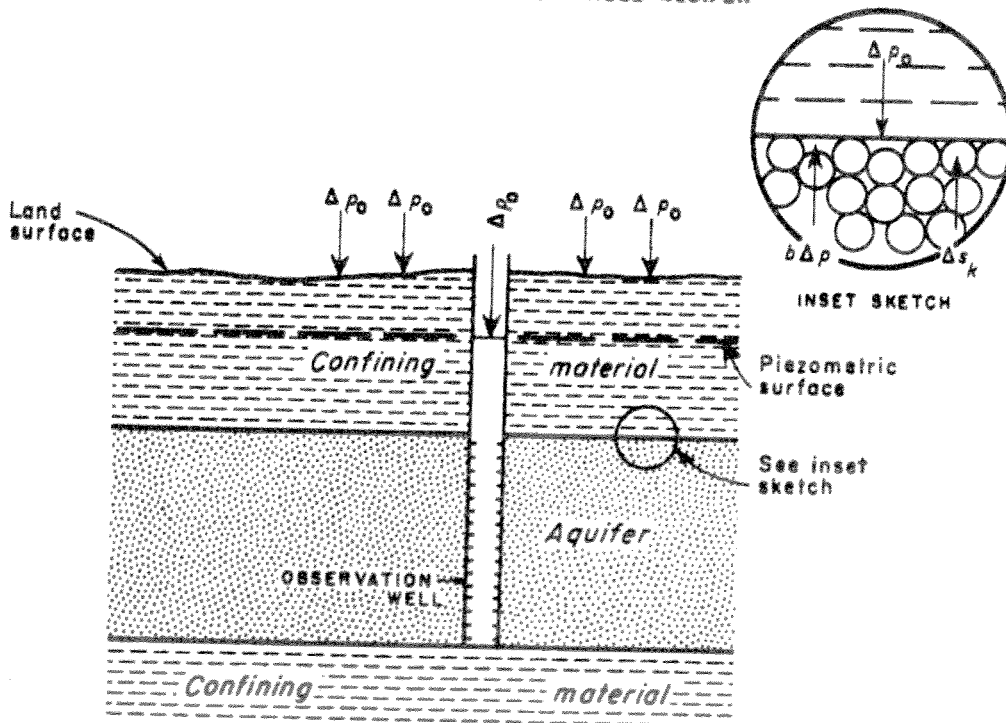

B. IDEALIZED SECTION OF ARTESIAN AQUIFER

FIGURE 22.—Effect of atmospheric pressure loading on aquifers.

Referring to diagram *A*, figure 22, the force  $\Delta p_0$ , representing the change in atmospheric pressure, is exerted on the free water surface in the well. The same force  $\Delta p_0$  is also exerted simultaneously on the water table because there is direct communication between the atmosphere and the water table through the unsaturated pore space of the soil. Thus the system of forces remains in balance and there is no appreciable change in water level in the well with changes in atmospheric pressure. Some water-table wells exhibit barometric fluctuations if the soil is frozen or saturated with water. But either of these conditions is, in effect, only a special case of the artesian condition.

Referring to diagram *B*, figure 22, the force  $\Delta p_0$ , which again represents the change in atmospheric pressure, acts on the free water surface in the well and also on the layer of material confining the artesian aquifer. Jacob (1940) in discussing this situation, reasons that barometric fluctuations in a well are an index of the elasticity of the aquifer. In other words the confining layer, viewed as a unit, has no beam strength or resistance to deflection sufficient to withstand or contain any sensible part of an applied load. Thus in effect any changes in the atmospheric pressure loading on a confining layer are transmitted through it undiminished in magnitude. The forces acting at a point at the interface between the aquifer and the confining layer may then be drawn as shown in the inset sketch. Observe that the change in atmospheric pressure,  $\Delta p_0$ , is now accommodated by a change in stress in the skeleton of the aquifer,  $\Delta s_s$ , plus a change in the water pressure in the aquifer,  $\Delta p$ , applied over the percentage  $b$  of the interface, where the water is in direct contact with the confining layer. It is evident, therefore, that in an artesian situation there will be a pressure differential between an observation well where the water is directly subject to the full change in atmospheric pressure, and a point out in the aquifer where the water is required to accept only part of the change in atmospheric pressure. Thus barometric fluctuations will be observed in the well. Some wells near the outcrop of an artesian aquifer or near a discontinuity in the confining layer will show little or no response to atmospheric pressure changes.

Although not associated with the elasticity of artesian aquifers, it is interesting to note that the phenomena of blowing and sucking wells, which exhibit a pronounced updraft or downdraft of air at the well mouth, may also be related to changes in atmospheric pressure. In areas where such wells have been noted, a bed of fine-grained, relatively impermeable material usually lies some distance above the water table, thereby effectively confining, in the intervening un-

saturated pore space, a body of air that can communicate with the atmosphere only through wells.

The barometric efficiency of an aquifer may be expressed as

$$BE = \frac{s_w}{s_b}$$

where  $s_w$  is the net change in water level observed in a well tapping the aquifer and  $s_b$  is the corresponding net change in atmospheric pressure, both expressed in feet of water. It is frequently convenient to determine the barometric efficiency by plotting the water-level changes as ordinates and the corresponding changes in atmospheric pressure as abscissas on rectangular coordinate paper. The slope of the straight line drawn through the plotted points is the barometric efficiency.

#### TIDAL FLUCTUATIONS OCEAN, LAKE, OR STREAM TIDES

Water levels in wells near the ocean or near some lakes or streams exhibit semidiurnal fluctuations in response to tidal fluctuations. In wells tapping water-table aquifers, the water-level response to tidal fluctuations is due to actual movement of water in the aquifer. However, in wells tapping artesian aquifers that are effectively separated from the body of surface water by an extensive confining layer, the response is due to the changing load on the aquifer, transmitted through the confining layer with the changing tide. Thus with the rise of the tide the load on the aquifer is increased, which means that in the aquifer there will be compensating increases of the water pressure and of the stress in the skeleton. Accordingly, the water-level rise in the well is but a reflection of the increased pressure head in the aquifer caused by the tidal loading.

An artesian well that responds to tidal fluctuations should also respond to changes in atmospheric pressure, because the same mechanism in the aquifer produces both types of response.

The tidal efficiency of an aquifer may be expressed as

$$TE = \frac{s_w}{s_t}$$

where  $s_w$  is the range of water-level fluctuation, in feet, in a well tapping the aquifer, and  $s_t$  is the range of the tide, in feet, corrected for density when necessary. There is a direct relation between the tidal efficiency or the barometric efficiency and the coefficient of storage. This relation will be discussed in a later section of this report.

Jacob (1950, p. 331-332) has derived expressions relating the tidal and barometric efficiency and the elasticity of an artesian aquifer. The two pertinent equations are

$$TE = \frac{\alpha/\theta\beta}{1 + \alpha/\theta\beta}$$

and

$$BE = \frac{1}{1 + \alpha/\theta\beta}$$

where  $\alpha$  is the bulk modulus of compression of the solid skeleton of the aquifer,  $\beta$  is the bulk modulus of compression of water (reciprocal of the bulk modulus of elasticity), and  $\theta$  is the porosity of the aquifer. If these two equations are added it is evident that the sum of the barometric efficiency and the tidal efficiency equals unity, that is,

$$BE + TE = 1$$

#### EARTH TIDES

It has been observed that earth tides, which are caused by the forces exerted on the earth's surface by the sun and the moon, may produce water-level fluctuations in artesian wells. Water-level fluctuations due to earth tides were apparently first observed by Klönne (1880) in a flooded coal mine at Dux, Bohemia. Such fluctuations in wells were first observed by Young (1913) near Cradock, South Africa. After the water levels have been adjusted for changes in atmospheric pressure the "high" water levels have been observed near moonrise and moonset and the "low" water levels near the upper and lower culminations of the moon.

For a well near Carlsbad, New Mexico, and for a well at Iowa City, Iowa, Robinson (1939) showed that the water-level fluctuations, after adjustment for changes in atmospheric pressure, are coincident with the earth tides. The low water levels showed a tendency to precede the culmination of the moon, suggesting that the tide in the well precedes the culmination of the moon.

According to Theis (1939), the possible effects of tidal forces acting either directly upon the water in the aquifer or upon the aquifer itself by varying the weight of the overburden could not account for the observed water-level fluctuations. The explanation for these water-level fluctuations is probably the distortion of the earth's crust. In this regard Theis (1939) states:

As the crust of the earth in any given area rises and falls with the deformation of the earth caused by the tidal forces the crust is most probably alternately

expanded and compressed laterally—expanded when the earth bulges up and compressed when it subsides. Water in an artesian aquifer making up part of the crust shares in this deformation. In localities distant from points of outflow of the water, it is in effect confined without possibility of outflow within the period of tidal fluctuations. The slight hydraulic gradient imposed by the tidal distortion is too small to cause effective release of pressure. Hence the aquifer is essentially sealed with respect to its included fluid. With the expansion of the aquifer incident to the tidal bulge the hydrostatic pressure falls and with its compression incident to tidal depression the hydrostatic pressure rises.

#### EARTHQUAKES

Fluctuations in water levels due to earthquakes have been observed in many wells equipped with water-stage recorders. Veatch (1906, p. 70) was apparently one of the first hydrologists in this country to recognize that some water-level fluctuations might be in response to earthquake disturbances. Subsequent investigators who have published papers on the subject include H. T. Stearns (1928), Piper (1933), Leggett and Taylor (1935), LaRocque (1941), Parker and Stringfield (1950), and Vorhis (1953). An earthquake may be defined as a vibration or oscillation of the earth's crust caused by a transient disturbance of the elastic or gravitational equilibrium of the rocks at or beneath the land surface. Earthquakes are classified as shallow or deep depending on the vertical position, relative to the land surface, of the source of the disturbance. Shock waves, propagated by an earthquake, travel through the earth and along the earth's surface. Because the earth is an elastic body it is first compressed by the shock waves and subsequently it expands after the shock wave is dissipated. Where an aquifer is included in the segment of the earth affected by the shock waves of an earthquake there will first be an abrupt increase in water pressure as the water assumes part of the imposed compressive stress, followed by an abrupt decrease in water pressure as the imposed stress is removed. In attempting to adjust to the pressure changes, the water level in an artesian well first rises and then falls. The amounts of the rise and fall of the water level, with respect to the initial position, are approximately the same. Cases have been recorded, however, where the water level did not return to its initial position (Brown, 1948, p. 193-195). This is presumably due to permanent rearrangement of the grains of material composing the aquifer. Fluctuations of greater magnitude have been observed in wells in limestone aquifers than in wells in granular material.

The following table gives the types of shock waves caused by earthquakes, the approximate average velocities at which they travel and the path they take.

TABLE 1.—*Approximate average velocities and paths taken by different types of shock waves caused by earthquakes*

[After Byerly, P., 1933, p. 155]

Type of shock wave	Approximate average velocity				Path
	(km per sec)	(ft per sec)	(mi per min)	(mi per hr)	
Deep-seated.....	5.5	18,000±	205±	12,030±	Chord Arc
Surface.....	3.2	10,500±	120±	7,200±	

**COEFFICIENT OF STORAGE AND ITS RELATION TO ELASTICITY**

The coefficient of storage is a function of the elasticity of an artesian aquifer. Jacob (1950) has expressed the relation as

$$S = \gamma_0 \theta m \left( \beta + \frac{\alpha}{\theta} \right)$$

where in this instance  $\gamma_0$  is the specific weight of the water at a stated reference temperature, and  $\theta$ ,  $m$ ,  $\beta$ , and  $\alpha$  are as defined earlier in this report. This formula assumes no leakage from or into contiguous beds.

Digressing momentarily, the specific weight,  $\gamma$ , of a fluid at a stated reference temperature is defined as its density,  $\rho$ , multiplied by the local acceleration due to gravity,  $g$ . Stated another way, it is the weight per unit volume that takes into account the magnitude of the local gravitational force. The manner in which specific weight is related to such more commonly used properties as mass, weight, and density can be developed in the following fashion. First it should be recognized that in the English engineering system the unit of mass is termed a "slug". It is the mass in which an acceleration of 1 ft per sec per sec. is produced by a force of 1 lb. Thus 1 slug of mass is approximately equal to 32.2 lb of mass. The mass,  $M$ , in slugs, of any substance is determined from the relation

$$M = \frac{W}{g}$$

where  $W$  is the weight of the substance in pounds. Inasmuch as weight is dependent on the local gravitational force it obviously varies with location. Thus, the fraction  $W/g$  takes into account in both numerator and denominator the local force of gravity, which shows that mass is an absolute property that does not change with location. Density is defined as mass per unit volume,  $V$ . That is:

$$\text{Density} = \frac{M}{V}$$



Thus density also is an absolute property that does not change with location. (Slight changes occur with change in temperature but ordinarily, within the range of ground-water temperatures encountered, no adjustment for this factor is necessary.) If the original relation given for determining mass,  $M$ , is solved for the weight,  $W$ , and if both sides of the rewritten equation are divided by the volume,  $V$ , there follows:

$$\left[\frac{W}{V}\right] = \left[\frac{M}{V}\right] g$$

The brackets on the left side of the equation are now seen to include the fraction equivalent to specific weight and the brackets on the right side include the fraction equivalent to density. That is:

$$\gamma = \rho g$$

Returning to the discussion at hand, it is important to point out that considerable study remains to be done regarding the elastic behavior of artesian reservoirs. It would be worthwhile, for example, to compute the values of the bulk modulus of compression ( $\alpha$ ) of the solid skeleton of the various artesian reservoirs where coefficients of storage have been determined from various types of aquifer tests. R. R. Bennett (oral communication) has supplied the following data for the principal aquifer in the Baltimore, Md., area:

$$S = 0.0002$$

$$\theta = 0.30$$

$$m = 100 \text{ feet} = 1200 \text{ inches}$$

Recognizing that for water

$$\gamma_0 = 62.4 \text{ lbs per cu ft} = \frac{62.4}{1728} \text{ (or } 0.0361 \text{ lb per cu in)}$$

and

$$\beta = \frac{1}{300,000} = 3.3 \times 10^{-6} \text{ (sq in per lb)}$$

appropriate substitution of all known quantities is made in Jacob's equation for the storage coefficient and the value of  $\alpha$  is computed. Thus

$$0.0002 = (0.0361)(0.30)(1200) \left[ 0.0000033 + \frac{\alpha}{0.30} \right]$$

or

$$\alpha = 0.00000363 \text{ sq in per lb or } 3.63 \times 10^{-6} \text{ sq in per lb}$$

Conversely, it is possible to determine the coefficient of storage if  $\alpha$  is

known. Jacob (1941) determined from pumping tests that the modulus of compression ( $\alpha$ ) of the Lloyd sand member of the Raritan formation on Long Island, N.Y., was  $2.1 \times 10^{-6}$  in per lb. In a location where this sand has a porosity ( $\theta$ ) of 0.30 and is confined to form an aquifer having a thickness ( $m$ ) of 50 feet the coefficient of storage may be computed as

$$S = (0.0361)(0.30)(50 \times 12) \left[ (3.3 \times 10^{-6}) + \frac{2.1 \times 10^{-6}}{0.30} \right]$$

$$S = 6.7 \times 10^{-5}$$

The coefficient of storage is related to barometric and tidal efficiency. As stated previously, Jacob (1940) showed mathematically that the sum of the barometric efficiency and tidal efficiency must equal unity ( $BE + TE = 1$ ). He showed further that when  $b = 1$  the storage coefficient is related to the barometric efficiency as follows,

$$S = (\gamma_0 \theta m \beta) \left[ \frac{1}{BE} \right]$$

using the same terminology as before and assuming no leakage from or into contiguous beds. By observing tidal fluctuations in a well, screened in the Lloyd sand member of the Raritan formation on Long Island, Jacob (1940) could then determine tidal efficiency and compute the coefficient of storage. His computations for well Q-288, near Rockaway Park, where the tidal efficiency was determined as 42 percent, are as follows:

$$\frac{1}{BE} = \frac{1}{1 - (TE)} = \frac{1}{1 - 0.42} = 1.72.$$

Ascribing a thickness of 200 feet and a porosity of 0.35 to the Lloyd sand member in the vicinity of Rockaway Park, Long Island, and substituting in the foregoing equation for storage coefficient, there results—

$$S = (0.0361)(0.35)(200 \times 12) \left[ \frac{1}{300,000} \right] (1.72),$$

$$S = 1.7 \times 10^{-4}.$$

This value for the coefficient of storage is comparable to the values determined from pumping tests.

Jacob (1941) observed that the compressibility of the Lloyd sand member, as computed from a discharging-well test, was about  $2\frac{1}{2}$  times that computed from tidal fluctuations and reasoned that this

disparity might be due, in part, to the range of stress involved. He states—

\* \* \* during the pumping test of 1940 the head in the Lloyd sand declined to a new low over a considerable area in the vicinity of the pumped wells, and consequently the stress in the skeleton of the aquifer reached a new high. It is to be expected that the modulus of elasticity would be smaller for the new, higher range of stress than for the old range over which the stress had fluctuated many times.

### AQUIFER TESTS—BASIC THEORY

#### WELL METHODS—POINT SINK OR POINT SOURCE

##### CONSTANT DISCHARGE OR RECHARGE WITHOUT VERTICAL LEAKAGE EQUILIBRIUM FORMULA

Wenzel (1942, p. 79–82) showed that the equilibrium formulas used by Slichter (1899), Turneaure and Russell (1901), Israelson (1950), and Wyckoff, Botset, and Muskat (1932) are essentially modified forms of a method developed by Thiem (1906), as are the formulas developed by Dupuit (1848) and Forchheimer (1901). Thiem apparently was the first to use the equilibrium formula for determining permeability and it is frequently associated with his name. The formula was developed by Thiem from Darcy's law and provides a means for determining aquifer transmissibility if the rate of discharge of a pumped well and the drawdown in each of two observation wells at different known distances from the pumped well are known. The Thiem formula, in nondimensional form, can be written as

$$T = \frac{Q \log_e (r_2/r_1)}{2\pi(s_1 - s_2)}, \quad (1)$$

where the subscript  $e$  in the log term indicates the natural logarithm. In the usual Geological Survey units (see p. 73), and using common logarithms, equation 1 becomes

$$T = \frac{527.7Q \log_{10} (r_2/r_1)}{s_1 - s_2}, \quad (2)$$

where

$T$  = coefficient of transmissibility, in gallons per day per foot,  
 $Q$  = rate of discharge of the pumped well, in gallons per minute,  
 $r_1$  and  $r_2$  = distances from the pumped well to the first and second observation wells, in feet, and  
 $s_1$  and  $s_2$  = drawdowns in the first and second observation wells, in feet.

The derivation of the formula is based on the following assumptions:  
 (a) the aquifer is homogeneous, isotropic, and of infinite areal extent;  
 (b) the discharging well penetrates and receives water from the entire thickness of the aquifer; (c) the coefficient of transmissibility is constant at all times and at all places; (d) pumping has continued at a

uniform rate for sufficient time for the hydraulic system to reach a steady-state (i.e., no change in rate of drawdown as a function of time) condition; and (e) the flow is laminar. The formula has wide application to ground-water problems despite the restrictive assumptions on which it is based.

The procedure for application of equation 2 is to select some convenient elapsed pumping time,  $t$ , after reaching the steady-state condition, and on semilog coordinate paper plot for each observation well the drawdowns,  $s$ , versus the distances,  $r$ . By plotting the values of  $s$  on the arithmetic scale and the values of  $r$  on the logarithmic scale, the observed data should lie on a straight line for the equilibrium formula to apply. From this straight line an arbitrary choice of  $s_1$  and  $s_2$  should be made and the corresponding values of  $r_1$  and  $r_2$  recorded. Equation 2 can then be solved for  $T$ .

Jacob (1950, p. 368) recognized that the coefficient of storage could also be determined if the hydraulic system had reached a steady-state condition (see assumption d, above), for thereafter the drawdown is expressed very closely by the nondimensional formula

$$s = \frac{Q}{4\pi T} \log_e \frac{2.25Tt}{r^2 S} \quad (3)$$

or, in the usual Survey units and using common logarithms,

$$s = \frac{264Q}{T} \log_{10} \frac{0.3Tt}{r^2 S} \quad (4)$$

Thus after the coefficient of transmissibility has been determined, the coordinates of any point on the semilogarithmic graph previously described can be used to solve equation 4 for the coefficient of storage.

#### Nonequilibrium Formula

Theis (1935) derived the nonequilibrium formula from the analogy between the hydrologic conditions in an aquifer and the thermal conditions in an equivalent thermal system. The analogy between the flow of ground water and heat conduction for the steady-state condition has been recognized at least since the work of Slichter (1899), but Theis was the first to introduce the concept of time to the mathematics of ground-water hydraulics. Jacob (1940) verified the derivation of the nonequilibrium formula directly from hydraulic concepts.

The nonequilibrium formula in nondimensional form is

$$s = \frac{Q}{4\pi T} \int_{r^2 S / 4Tt}^{\infty} \frac{e^{-u}}{u} du, \quad (5)$$

where  $u = r^2 S / 4Tt$ , and where the integral expression is known as an exponential integral.

Using the ordinary Survey units equation 5 may be written as

$$s = \frac{114.6Q}{T} \int_{1.87r^2S/Tt}^{\infty} \frac{e^{-u}}{u} du, \tag{6}$$

where

- $u = 1.87r^2S/Tt$ ,
- $s$  = drawdown, in feet, at any point of observation in the vicinity of a well discharging at a constant rate,
- $Q$  = discharge of a well, in gallons per minute,
- $T$  = transmissibility, in gallons per day per foot,
- $r$  = distance, in feet, from the discharging well to the point of observation,
- $S$  = coefficient of storage, expressed as a decimal fraction,
- $t$  = time in days since pumping started.

The nonequilibrium formula is based on the following assumptions: (a) the aquifer is homogeneous and isotropic; (b) the aquifer has infinite areal extent; (c) the discharge or recharge well penetrates and receives water from the entire thickness of the aquifer; (d) the coefficient of transmissibility is constant at all times and at all places; (e) the well has an infinitesimal (reasonably small) diameter; and (f) water removed from storage is discharged instantaneously with decline in head. Despite the restrictive assumptions on which it is based, the nonequilibrium formula has been applied successfully to many problems of ground-water flow.

The integral expression in equation 6 cannot be integrated directly, but its value is given by the series

$$\int_{1.87r^2S/Tt}^{\infty} \frac{e^{-u}}{u} du = W(u) = -0.577216 - \log_e u + u - \frac{u^2}{2 \cdot 2!} + \frac{u^3}{3 \cdot 3!} - \frac{u^4}{4 \cdot 4!} + \dots \tag{7}$$

where, as already indicated,

$$u = \frac{1.87r^2S}{Tt} \tag{8}$$

The exponential integral is written symbolically as  $W(u)$  which is read "well function of  $u$ ." Values of  $W(u)$  for values of  $u$  from  $10^{-16}$  to 9.9, as tabulated in Wenzel (1942), are given in table 2. In order to determine the value of  $W(u)$  for a given value of  $u$ , using table 2, it is necessary to express  $u$  as some number ( $N$ ) between 1.0 and 9.9, multiplied by 10 with the appropriate exponent. For example, when  $u$  has a value of 0.0005 (that is,  $5.0 \times 10^{-4}$ ),  $W(u)$  is

determined from the line  $N=5.0$  and the column  $N \times 10^{-4}$  to be 7.0242.

Referring to equations 6 and 8, if  $s$  can be measured for one value of  $r$  and several values of  $t$ , or for one value of  $t$  and several values of  $r$ , and if the discharge  $Q$  is known, then  $S$  and  $T$  can be determined. Once these aquifer constants have been determined, it is possible, theoretically, to compute the drawdown for any time at any point on the cone of depression for any given rate and distribution of pumping from wells. It is not possible, however, to determine  $T$  and  $S$  directly from equation 6, because  $T$  occurs in the argument of the function and again as a divisor of the exponential integral. This devised a convenient graphical method of superposition that makes it possible to obtain a simple solution of the equation.

The first step in this method is the plotting of a type curve on logarithmic coordinate paper. From table 2 values of  $W(u)$  have been plotted against the argument  $u$  to form the type curve shown in figure 23. It is shown in two segments, A-A and B-B, in order that the portion of the type curve necessary in the analysis of pumping test data could be plotted on a sheet of convenient size. Curve B-B is an extension of curve A-A and overlaps curve A-A for values of  $W(u)$  from about 0.22 to 1.0.

Rearranging equations 6 and 8 there follows

$$s = \left[ \frac{114.6Q}{T} \right] W(u) \quad (9)$$

or

$$\log s = \left[ \log \frac{114.6Q}{T} \right] + \log W(u) \quad (9a)$$

and

$$\frac{r^2}{t} = \left[ \frac{T}{1.87S} \right] u \quad (10)$$

or

$$\log \frac{r^2}{t} = \left[ \log \frac{T}{1.87S} \right] + \log u \quad (10a)$$

If the discharge,  $Q$ , is held constant, the bracketed parts of equations 9a and 10a are constant for a given pumping test, and  $W(u)$  is related to

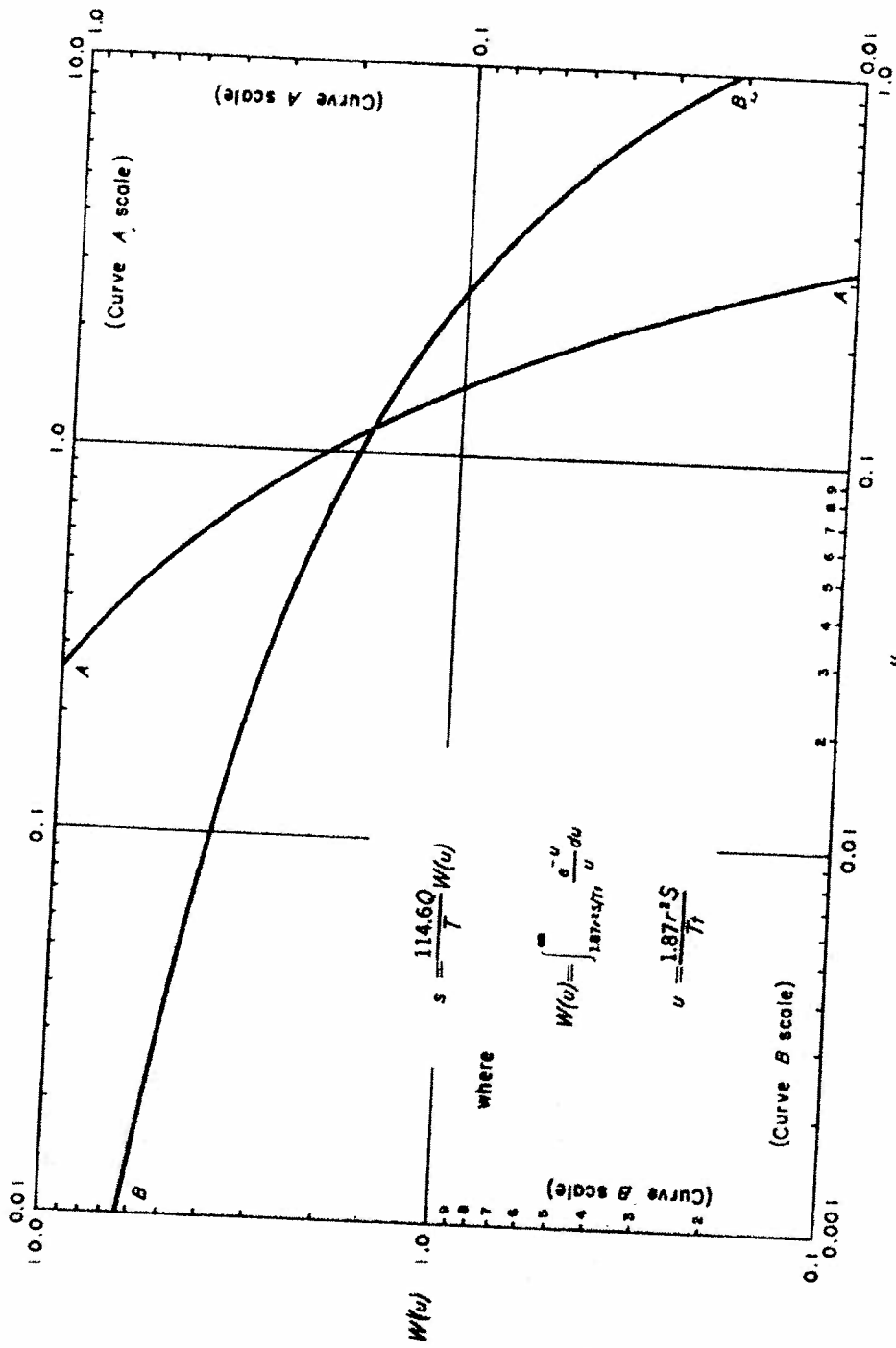

FIGURE 23.—Logarithmic graph of the well function  $W(u)$ —constant discharge

TABLE 2.—Values of  $W(u)$  for values of  $u$  between  $10^{-18}$  and  $9$ .

$u$	$N \times 10^{-18}$	$N \times 10^{-16}$	$N \times 10^{-14}$	$N \times 10^{-12}$	$N \times 10^{-10}$	$N \times 10^{-8}$	$N \times 10^{-6}$	$N \times 10^{-4}$	$N \times 10^{-2}$	$N$					
1.0	33.9316	29.3564	27.0538	24.7512	22.4486	20.1460	17.8435	15.5409	13.2383	10.9357	8.6332	6.3315	4.0279	1.8229	0.2194
1.1	33.9662	29.2611	26.9585	24.6569	22.3543	20.0507	17.7482	15.4456	13.1430	10.8404	8.5379	6.2353	3.9436	1.7371	0.1960
1.2	33.7792	29.1741	26.8716	24.5699	22.2663	19.9637	17.6611	15.3586	13.0560	10.7534	8.4508	6.1494	3.8578	1.6515	0.1844
1.3	33.6992	29.0940	26.7914	24.4889	22.1833	19.8837	17.5811	15.2735	12.9750	10.6734	8.3708	6.0693	3.7755	1.5699	0.1735
1.4	33.6261	29.0199	26.7173	24.4147	22.1122	19.8086	17.5070	15.2044	12.9018	10.5983	8.2898	5.9935	3.7054	1.4941	0.1632
1.5	33.5581	28.9509	26.6493	24.3458	22.0432	19.7406	17.4380	15.1354	12.8328	10.5263	8.2278	5.9266	3.6374	1.4245	0.1534
1.6	33.4916	28.8804	26.5838	24.2812	21.9766	19.6780	17.3735	15.0709	12.7683	10.4583	8.1634	5.8621	3.5739	1.3613	0.1441
1.7	33.4309	28.8258	26.5232	24.2206	21.9180	19.6184	17.3128	15.0103	12.7077	10.4051	8.1027	5.8016	3.5143	1.3042	0.1352
1.8	33.3738	28.7686	26.4660	24.1634	21.8608	19.5633	17.2557	14.9531	12.6505	10.3479	8.0455	5.7446	3.4581	1.2528	0.1268
1.9	33.3197	28.7145	26.4110	24.1094	21.8068	19.5142	17.2016	14.8990	12.6064	10.2939	7.9915	5.6906	3.4060	1.2049	0.1189
2.0	33.2684	28.6632	26.3607	24.0581	21.7555	19.4629	17.1503	14.8477	12.5651	10.2426	7.9402	5.6394	3.3547	1.1602	0.1114
2.1	33.2196	28.6145	26.3119	24.0093	21.7067	19.4141	17.1015	14.7989	12.5264	10.1938	7.8914	5.5907	3.3069	1.1197	0.1043
2.2	33.1731	28.5679	26.2653	23.9628	21.6602	19.3676	17.0560	14.7524	12.4898	10.1473	7.8449	5.5443	3.2614	1.0814	0.0979
2.3	33.1286	28.5235	26.2209	23.9183	21.6167	19.3231	17.0106	14.7080	12.4454	10.1028	7.8004	5.4999	3.2179	1.0454	0.0921
2.4	33.0861	28.4809	26.1783	23.8758	21.5732	19.2806	16.9680	14.6654	12.4034	10.0603	7.7579	5.4575	3.1763	1.0113	0.0869
2.5	33.0453	28.4401	26.1375	23.8349	21.5323	19.2398	16.9272	14.6246	12.3628	10.0203	7.7172	5.4176	3.1365	0.9789	0.0821
2.6	33.0060	28.4009	26.0983	23.7957	21.4931	19.1995	16.8880	14.5854	12.3228	10.0194	7.6779	5.3778	3.0983	0.9481	0.0777
2.7	32.9683	28.3631	26.0606	23.7580	21.4554	19.1628	16.8502	14.5476	12.2828	9.9802	7.6401	5.3400	3.0616	0.9189	0.0731
2.8	32.9319	28.3268	26.0242	23.7216	21.4190	19.1284	16.8138	14.5113	12.2450	9.9425	7.6037	5.3037	3.0261	0.8902	0.0686
2.9	32.8968	28.2917	25.9891	23.6865	21.3839	19.0913	16.7788	14.4762	12.2106	9.9061	7.5687	5.2687	2.9920	0.8628	0.0643
3.0	32.8629	28.2578	25.9552	23.6526	21.3500	19.0474	16.7449	14.4423	12.1786	9.8710	7.5348	5.2349	2.9591	0.8361	0.0602
3.1	32.8302	28.2250	25.9224	23.6198	21.3172	19.0146	16.7121	14.4095	12.1489	9.8363	7.5020	5.2022	2.9273	0.8105	0.0562
3.2	32.7984	28.1932	25.8907	23.5880	21.2855	18.9829	16.6803	14.3777	12.1201	9.8018	7.4703	5.1706	2.8965	0.7859	0.0524
3.3	32.7676	28.1625	25.8590	23.5573	21.2547	18.9521	16.6495	14.3470	12.0924	9.7678	7.4395	5.1399	2.8668	0.7621	0.0487
3.4	32.7378	28.1326	25.8280	23.5274	21.2249	18.9223	16.6197	14.3171	12.0656	9.7350	7.4097	5.1102	2.8379	0.7391	0.0452
3.5	32.7088	28.1036	25.7978	23.4985	21.1959	18.8933	16.5907	14.2881	12.0400	9.7030	7.3807	5.0813	2.8099	0.7167	0.0418
3.6	32.6806	28.0755	25.7729	23.4703	21.1677	18.8651	16.5625	14.2599	12.0154	9.6714	7.3528	5.0532	2.7827	0.6949	0.0385
3.7	32.6532	28.0481	25.7455	23.4429	21.1403	18.8377	16.5351	14.2325	11.9910	9.6407	7.3252	5.0259	2.7554	0.6735	0.0353
3.8	32.6266	28.0214	25.7188	23.4162	21.1136	18.8110	16.5085	14.2059	11.9674	9.6107	7.2986	5.0000	2.7286	0.6526	0.0322
3.9	32.6006	27.9954	25.6928	23.3902	21.0877	18.7851	16.4825	14.1799	11.9433	9.5807	7.2725	4.9745	2.7020	0.6321	0.0292
4.0	32.5753	27.9701	25.6676	23.3649	21.0623	18.7598	16.4572	14.1546	11.9193	9.5515	7.2473	4.9495	2.6764	0.6120	0.0263
4.1	32.5506	27.9454	25.6428	23.3402	21.0376	18.7351	16.4325	14.1300	11.8950	9.5270	7.2225	4.9250	2.6513	0.5923	0.0235
4.2	32.5263	27.9213	25.6187	23.3161	21.0136	18.7110	16.4084	14.1058	11.8711	9.5028	7.1985	4.8997	2.6264	0.5730	0.0208
4.3	32.5029	27.8978	25.5952	23.2926	20.9900	18.6874	16.3844	14.0823	11.8477	9.4791	7.1749	4.8762	2.6019	0.5541	0.0183
4.4	32.4800	27.8748	25.5722	23.2696	20.9670	18.6644	16.3619	14.0593	11.8240	9.4558	7.1517	4.8530	2.5779	0.5356	0.0159
4.5	32.4576	27.8523	25.5497	23.2471	20.9446	18.6420	16.3394	14.0368	11.8008	9.4326	7.1286	4.8300	2.5544	0.5174	0.0135
4.6	32.4355	27.8303	25.5277	23.2252	20.9226	18.6200	16.3174	14.0148	11.7782	9.4097	7.1055	4.8071	2.5313	0.5000	0.0113
4.7	32.4140	27.8088	25.5062	23.2037	20.9011	18.5985	16.2959	13.9933	11.7573	9.3872	7.0825	4.7844	2.5086	0.4831	0.0092
4.8	32.3929	27.7878	25.4852	23.1826	20.8800	18.5774	16.2748	13.9723	11.7366	9.3657	7.0599	4.7621	2.4863	0.4667	0.0072
4.9	32.3723	27.7672	25.4646	23.1620	20.8594	18.5568	16.2542	13.9516	11.7161	9.3445	7.0371	4.7406	2.4641	0.4508	0.0053



5.0	32.3521	30.0495	27.7470	25.4444	23.1415	20.8392	18.5366	16.2340	13.9314	11.6289	9.3263	7.0237	4.7211	2.4179	.5568	.001148
5.1	32.3523	30.0297	27.7271	25.4246	23.1220	20.8194	18.5168	16.2142	13.9116	11.6091	9.3065	7.0044	4.7044	2.4191	.5478	.001021
5.2	32.3129	30.0103	27.7077	25.4051	23.1026	20.8000	18.4973	16.1948	13.8923	11.5896	9.2871	6.9850	4.6871	2.4203	.5382	.000896
5.3	32.2639	30.0913	27.6887	25.3861	23.0835	20.7809	18.4783	16.1758	13.8732	11.5706	9.2681	6.9659	4.6681	2.4215	.5290	.000771
5.4	32.2152	30.0720	27.6700	25.3674	23.0648	20.7622	18.4596	16.1571	13.8545	11.5519	9.2494	6.9473	4.6493	2.4227	.5200	.000646
5.5	32.1668	30.0532	27.6516	25.3491	23.0463	20.7439	18.4413	16.1387	13.8361	11.5336	9.2310	6.9290	4.6313	2.4239	.5110	.000521
5.6	32.1185	30.0345	27.6336	25.3310	23.0285	20.7259	18.4233	16.1207	13.8181	11.5156	9.2130	6.9109	4.6134	2.4251	.5020	.000396
5.7	32.0711	30.0159	27.6159	25.3133	23.0108	20.7082	18.4056	16.1030	13.8004	11.4978	9.1953	6.8932	4.5958	2.4263	.4930	.000271
5.8	32.0237	30.0971	27.5985	25.2959	22.9934	20.6908	18.3882	16.0856	13.7830	11.4804	9.1779	6.8758	4.5785	2.4275	.4840	.000146
5.9	32.1896	30.0840	27.5814	25.2789	22.9763	20.6737	18.3711	16.0688	13.7659	11.4633	9.1608	6.8588	4.5616	2.4287	.4752	.000021
6.0	32.1498	30.0672	27.5646	25.2620	22.9595	20.6569	18.3543	16.0517	13.7491	11.4465	9.1440	6.8420	4.5448	2.4299	.4664	.000000
6.1	32.1353	30.0507	27.5481	25.2455	22.9429	20.6403	18.3378	16.0352	13.7326	11.4300	9.1275	6.8254	4.5280	2.4311	.4574	.000000
6.2	32.1210	30.0344	27.5318	25.2298	22.9267	20.6241	18.3215	16.0189	13.7163	11.4138	9.1112	6.8092	4.5122	2.4323	.4484	.000000
6.3	32.1068	30.0184	27.5158	25.2143	22.9107	20.6081	18.3055	16.0029	13.7003	11.3978	9.0952	6.7932	4.4964	2.4335	.4394	.000000
6.4	32.0928	30.0027	27.5001	25.1993	22.8949	20.5923	18.2896	15.9872	13.6846	11.3820	9.0795	6.7775	4.4804	2.4347	.4304	.000000
6.5	32.0789	30.0872	27.4846	25.1840	22.8794	20.5768	18.2742	15.9717	13.6691	11.3663	9.0640	6.7620	4.4644	2.4359	.4214	.000000
6.6	32.0650	30.0719	27.4693	25.1687	22.8641	20.5616	18.2590	15.9564	13.6538	11.3512	9.0487	6.7467	4.4484	2.4371	.4124	.000000
6.7	32.0512	30.0566	27.4543	25.1537	22.8491	20.5465	18.2439	15.9414	13.6388	11.3363	9.0337	6.7317	4.4324	2.4383	.4034	.000000
6.8	32.0374	30.0413	27.4395	25.1389	22.8343	20.5317	18.2291	15.9265	13.6240	11.3214	9.0189	6.7169	4.4164	2.4395	.3944	.000000
6.9	32.0236	30.0260	27.4249	25.1243	22.8197	20.5171	18.2145	15.9119	13.6094	11.3068	9.0043	6.7023	4.4004	2.4407	.3854	.000000
7.0	32.0100	30.0118	27.4105	25.1100	22.8053	20.5027	18.2001	15.8976	13.5950	11.2924	8.9899	6.6879	4.3844	2.4419	.3764	.000000
7.1	32.0015	30.0980	27.3963	25.0957	22.7911	20.4885	18.1860	15.8834	13.5808	11.2782	8.9757	6.6737	4.3684	2.4431	.3674	.000000
7.2	31.9875	30.0840	27.3822	25.0817	22.7771	20.4746	18.1720	15.8694	13.5668	11.2642	8.9617	6.6596	4.3524	2.4443	.3584	.000000
7.3	31.9737	30.0701	27.3683	25.0679	22.7633	20.4608	18.1582	15.8556	13.5530	11.2504	8.9479	6.6456	4.3364	2.4455	.3494	.000000
7.4	31.9601	30.0563	27.3549	25.0543	22.7497	20.4472	18.1446	15.8420	13.5394	11.2368	8.9343	6.6324	4.3204	2.4467	.3404	.000000
7.5	31.9467	30.0427	27.3415	25.0409	22.7363	20.4337	18.1311	15.8296	13.5260	11.2234	8.9209	6.6190	4.3044	2.4479	.3314	.000000
7.6	31.9334	30.0293	27.3282	25.0277	22.7231	20.4205	18.1179	15.8173	13.5127	11.2102	8.9076	6.6057	4.2884	2.4491	.3224	.000000
7.7	31.9203	30.0160	27.3152	25.0146	22.7100	20.4074	18.1048	15.8052	13.4997	11.1971	8.8946	6.5927	4.2724	2.4503	.3134	.000000
7.8	31.9074	30.0028	27.3023	25.0016	22.6971	20.3945	18.0919	15.7933	13.4868	11.1842	8.8817	6.5798	4.2564	2.4515	.3044	.000000
7.9	31.8947	30.0892	27.2895	24.9889	22.6844	20.3818	18.0792	15.7816	13.4740	11.1714	8.8689	6.5671	4.2404	2.4527	.2954	.000000
8.0	31.8821	30.0759	27.2769	24.9744	22.6718	20.3692	18.0666	15.7700	13.4614	11.1589	8.8563	6.5545	4.2244	2.4539	.2864	.000000
8.1	31.8697	30.0627	27.2645	24.9619	22.6594	20.3568	18.0542	15.7586	13.4490	11.1464	8.8439	6.5421	4.2084	2.4551	.2774	.000000
8.2	31.8574	30.0495	27.2523	24.9497	22.6471	20.3445	18.0419	15.7473	13.4367	11.1342	8.8317	6.5298	4.1924	2.4563	.2684	.000000
8.3	31.8453	30.0363	27.2401	24.9375	22.6350	20.3324	18.0298	15.7362	13.4246	11.1220	8.8195	6.5177	4.1764	2.4575	.2594	.000000
8.4	31.8333	30.0232	27.2282	24.9258	22.6230	20.3204	18.0178	15.7252	13.4126	11.1101	8.8078	6.5057	4.1604	2.4587	.2504	.000000
8.5	31.8213	30.0103	27.2163	24.9137	22.6112	20.3086	18.0060	15.7143	13.4008	11.0983	8.7967	6.4939	4.1444	2.4599	.2414	.000000
8.6	31.8096	30.0972	27.2046	24.9020	22.5995	20.2969	17.9943	15.7034	13.3891	11.0865	8.7840	6.4823	4.1284	2.4611	.2324	.000000
8.7	31.7982	30.0840	27.1931	24.8905	22.5879	20.2853	17.9827	15.6927	13.3776	11.0750	8.7725	6.4707	4.1124	2.4623	.2234	.000000
8.8	31.7868	30.0709	27.1816	24.8790	22.5763	20.2739	17.9713	15.6817	13.3661	11.0635	8.7610	6.4592	4.0964	2.4635	.2144	.000000
8.9	31.7755	30.0578	27.1703	24.8678	22.5652	20.2626	17.9600	15.6704	13.3546	11.0523	8.7497	6.4480	4.0804	2.4647	.2054	.000000
9.0	31.7643	30.0448	27.1592	24.8566	22.5540	20.2514	17.9488	15.6592	13.3437	11.0411	8.7386	6.4368	4.0644	2.4659	.1964	.000000
9.1	31.7533	30.0318	27.1481	24.8455	22.5429	20.2404	17.9378	15.6482	13.3326	11.0300	8.7275	6.4258	4.0484	2.4671	.1874	.000000
9.2	31.7424	30.0188	27.1372	24.8346	22.5320	20.2294	17.9268	15.6368	13.3217	11.0191	8.7166	6.4148	4.0324	2.4683	.1784	.000000
9.3	31.7315	30.0059	27.1264	24.8238	22.5212	20.2186	17.9160	15.6255	13.3109	11.0083	8.7058	6.4040	4.0164	2.4695	.1694	.000000
9.4	31.7208	30.0929	27.1157	24.8131	22.5105	20.2079	17.9053	15.6143	13.3002	10.9976	8.6951	6.3934	4.0004	2.4707	.1604	.000000
9.5	31.7103	30.0799	27.1051	24.8025	22.4999	20.1973	17.8948	15.6032	13.2896	10.9870	8.6845	6.3828	3.9844	2.4719	.1514	.000000
9.6	31.6998	30.0669	27.0946	24.7920	22.4892	20.1869	17.8843	15.5922	13.2791	10.9765	8.6740	6.3723	3.9684	2.4731	.1424	.000000
9.7	31.6894	30.0540	27.0840	24.7817	22.4785	20.1765	17.8739	15.5817	13.2688	10.9662	8.6637	6.3620	3.9524	2.4743	.1334	.000000
9.8	31.6792	30.0411	27.0740	24.7714	22.4688	20.1663	17.8637	15.5711	13.2585	10.9560	8.6534	6.3511	3.9364	2.4755	.1244	.000000
9.9	31.6690	30.0282	27.0639	24.7613	22.4587	20.1561	17.8535	15.5609	13.2483	10.9458	8.6433	6.3410	3.9204	2.4767	.1154	.000000

$u$  in the manner that  $s$  is related to  $r^2/t$ . This is shown graphically in figure 24. Therefore, if values of the drawdown  $s$  are plotted against  $r^2/t$ , or  $1/t$  if only one observation well is used, on logarithmic tracing paper to the same scale as the type curve, the curve of observed data will be similar to the type curve. The data curve may then be superposed on the type curve, the coordinate axes of the two curves being held parallel, and translated to a position which represents the best fit of the field data to the type curve. An arbitrary point is selected anywhere on the overlapping portion of the sheets and the coordinates of this common point on both sheets are recorded. It is often convenient to select a point whose coordinates are both 1. These data are then used with equations 9 and 10 to solve for  $T$  and  $S$ .

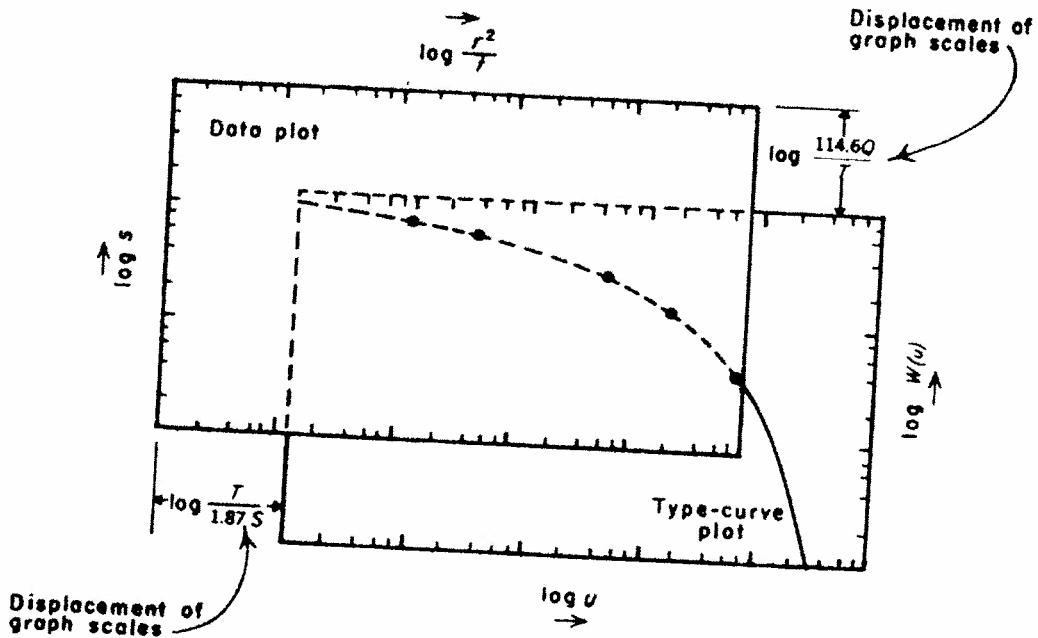

FIGURE 24.—Relation of  $W(u)$  and  $u$  to  $s$  and  $r^2/t$ .

A type curve on logarithmic coordinate paper of  $W(u)$  versus  $1/u$ , the reciprocal of the argument, could have been plotted. Values of the drawdown (or recovery),  $s$ , would then have been plotted versus  $t$ , or  $t/r^2$  and superposed on the type curve in the manner outlined above. This method eliminates the necessity for computing  $1/t$  values for the values of  $s$ .

#### MODIFIED NONEQUILIBRIUM FORMULA

It was recognized by Jacob (1950) that in the series of equation 7 the sum of the terms beyond  $\log u$  is not significant when  $u$  becomes small. The value of  $u$  decreases as the time,  $t$ , increases and as  $r$  decreases. Therefore, for large values of  $t$  and reasonably small

values of  $r$ , the terms beyond  $\log u$  in equation 7 may be neglected. When  $r$  is large,  $t$  must be very large before the terms beyond  $\log u$  in equation 7 can be neglected. Thus the Theis equation in its abbreviated or modified nondimensional form is written as

$$s = \frac{Q}{4\pi T} \left( \log_e \frac{4Tt}{r^2 S} - 0.5772 \right) \\ = \frac{Q}{4\pi T} \log_e \frac{2.25Tt}{r^2 S},$$

which is obviously identical with equation 3. In the usual Survey units, then, this equation will be identical with equation 4, all terms being as previously defined.

In applying equation 4 to measurements of the drawdown or recovery of water level in a particular observation well, the distance  $r$  will be constant, and it follows that

$$\text{at time } t_1, s_1 = \frac{264Q}{T} \left( \log_{10} \frac{0.3Tt_1}{r^2 S} \right); \\ \text{at time } t_2, s_2 = \frac{264Q}{T} \left( \log_{10} \frac{0.3Tt_2}{r^2 S} \right);$$

and the change in drawdown or recovery from time  $t_1$  to  $t_2$  is

$$s_2 - s_1 = \frac{264Q}{T} \left( \log_{10} \frac{t_2}{t_1} \right).$$

Rewriting this equation in form suitable for direct solution of  $T$ , there follows

$$T = \frac{264Q(\log_{10} t_2/t_1)}{s_2 - s_1}, \quad (11)$$

where  $Q$  and  $T$  are as previously defined,  $t_1$  and  $t_2$  are two selected times, in any convenient units, since pumping started or stopped, and  $s_1$  and  $s_2$  are the respective drawdowns or recoveries at the noted times, in feet.

The most convenient procedure for application of equation 11 is to plot the observed data for each well on the semilogarithmic coordinate paper, plotting values of  $t$  on the logarithmic scale and values of  $s$  on the arithmetic scale. After the value of  $u$  becomes small (generally less than 0.01) and the value of time,  $t$ , becomes great, the observed data should fall on a straight line. From this straight line make an arbitrary choice of  $t_1$  and  $t_2$  and record the corresponding values of  $s_1$  and  $s_2$ . Equation 11 can then be solved for  $T$ . For

convenience,  $t_1$  and  $t_2$  are usually chosen one log cycle apart, because then

$$\log_{10} \frac{t_2}{t_1} = 1$$

and equation 11 reduces to

$$T = \frac{264Q}{\Delta s}, \quad (12)$$

where  $\Delta s$  is the change, in feet, in the drawdown or recovery over one log cycle of time.

The coefficient of storage also can be determined from the same semilog plot of the observed data. When  $s=0$ , equation 3 becomes

$$s=0 = \frac{Q}{4\pi T} \log_e \frac{2.25Tt}{r^2 S}$$

Solving for the coefficient of storage,  $S$ , the equation in its final form becomes

$$S = \frac{2.25Tt}{r^2} \quad (13)$$

or, in the usual Survey units,

$$S = \frac{0.3Tt_0}{r^2}, \quad (14)$$

where  $S$ ,  $T$ , and  $r$  are as previously defined and  $t_0$  is the time intercept, in days, where the plotted straight line intersects the zero-drawdown axis. If any other units were used for the time,  $t$ , on the semilog plot, then obviously  $t_0$  must be converted to days before using equation 14. Lohman (1957) has described a simple method for determining  $S$  using the data region of the straight-line plot without extrapolating to the zero-drawdown axis.

#### THEIS RECOVERY FORMULA

A useful corollary to the nonequilibrium formula was devised by Theis (1935) for the analysis of the recovery of a pumped well. If a well is pumped, or allowed to flow, for a known period of time and then shut down and allowed to recover, the residual drawdown at any instant will be the same as if the discharge of the well had been continued but a recharge well with the same flow had been introduced at the same point at the instant the discharge stopped. The residual drawdown at any time during the recovery period is the difference between the observed water level and the nonpumping water level

extrapolated from the observed trend prior to the pumping period, The residual drawdown,  $s'$ , at any instant will then be

$$s' = \frac{114.6Q}{T} \left[ \int_{1.87r^2S/Tt}^{\infty} \frac{e^{-u}}{u} du - \int_{1.87r^2S/Tt'}^{\infty} \frac{e^{-u}}{u} du \right] \quad (15)$$

where  $Q$ ,  $T$ ,  $S$ , and  $r$  are as previously defined,  $t$  is the time since pumping started, and  $t'$  is the time since pumping stopped. The quantity  $1.87r^2S/Tt'$  will be small when  $t'$  ceases to be small because  $r$  is very small and therefore the value of the integral will be given closely by the first two terms of the infinite series of equation 7. Equation 15 can therefore be written, in modified form, in the usual Survey units, as

$$T = \frac{264Q}{s'} \log_{10} \frac{t}{t'} \quad (16)$$

The above formula is similar in form to, and is based on the same assumptions as, the modified nonequilibrium formula developed by Jacob, and it permits the computation of the coefficient of transmissibility of an aquifer from the observation of the rate of recovery of water level in a pumped well, or in a nearby observation well where  $r$  is sufficiently small to meet the above assumptions.

The Theis recovery formula is applied in much the same manner as the modified nonequilibrium formula. The most convenient procedure is to plot the residual drawdown,  $s'$ , against  $t/t'$  on semilogarithmic coordinate paper,  $s'$  being plotted on the arithmetic scale and  $t/t'$  on the logarithmic scale. After the value of  $t'$  becomes sufficiently large, the observed data should fall on a straight line. The slope of this line gives the value of the quantity  $\log_{10} (t/t')/s'$  in equation 16. For convenience, the value of  $t/t'$  is usually chosen over one log cycle because its logarithm is then unity and equation 16 then reduces to

$$T = \frac{264 Q}{\Delta s'} \quad (17)$$

where  $\Delta s'$  is the change in residual drawdown, in feet, per log cycle of time. It is not possible to determine the coefficient of storage from the observation of the rate of recovery of a pumped well unless the effective radius,  $r_w$ , which is usually difficult to determine, is known. The Theis recovery formula should be used with caution in areas where it is suspected that boundary conditions exist. If a geologic boundary has been intercepted by the cone of depression during pumping, it may be reflected in the rate of recovery of the pumped well, and the value of  $T$  determined by using the Theis recovery formula could be in error. With reasonable care the recovery in an observation well

can be used, of course, to determine both transmissibility and storage, whether or not boundaries are present.

#### APPLICABILITY OF METHODS TO ARTESIAN AND WATER-TABLE AQUIFERS

The methods previously discussed have been used successfully for many years in determining aquifer constants and in predicting the performance of both water-table and artesian aquifers. The derivations of the equations are based, in part, on the assumptions that the coefficient of transmissibility is constant at all times and places and that water is released from storage instantaneously with decline in head. It should be recognized, however, that these and many other idealizations are necessary before mathematical models can be used to analyze the physical phenomena associated with ground-water movement. Thus the hydrologist cannot blindly select a model, turn a crank, and accept the answers. He must devote considerable time and thought to judging how closely his real aquifer resembles the ideal. If enough data are available he will always find that no ideal aquifer, of the type postulated in the theory, could reproduce the data obtained in an actual pumping test. He should understand that the dispersion of the data is a measure of how far his aquifer departs from the ideal. Therefore, he must plan his test procedures so that they will conform as closely as possible to the theory and thus give results that can safely be applied to his aquifer. He must be prepared to find out, however, that his aquifer is too complex to permit a clear evaluation of its coefficients of transmissibility and storage. He must not tell himself or the reader that "the coefficient of storage changed" during the test but must realize that he got different values when he tried to apply his data, inconsistently, to an ideal theoretical aquifer.

Thus there is little justification for the premise that the storage coefficient of a water-table aquifer varies with the time of pumping, inasmuch as such anomalous data are merely the results of trying to apply a two-dimensional flow formula to a three-dimensional problem. The nonequilibrium formula was derived on the basis of strictly radial flow in an infinite aquifer and its application to situations where vertical-flow components occur is not justified except under certain limiting conditions. As the time of pumping becomes large, however, the rate of water-level decline decreases rapidly so that eventually the effect of vertical-flow components in water-table aquifers are minimized.

If the drawdowns are large compared to the initial depth of flow, it is necessary to adjust the observed drawdown in a pumping test of a water-table aquifer before the nonequilibrium formula is applied. According to Jacob (1944, p. 4) if the observed drawdowns are adjusted (reduced) by the factor  $s^2/2m$ , where  $s$  is the observed draw-

down and  $m$  is the initial depth of flow, the value of  $T$  will correspond to equivalent confined flow of uniform depth, and the value of  $S$  will more closely approximate the true value. He adds that when the drawdowns are adjusted the nonequilibrium formula can be used with fair assurance even when the dewatering is as much as 25 percent of the initial depth of flow.

Where the discharging well only partially penetrates the aquifer it may also be necessary to adjust the observed drawdowns. Procedures for accomplishing this have been described by Jacob (1945).

**INSTANTANEOUS DISCHARGE OR RECHARGE  
"BAILER" METHOD**

Skibitzke (1958) has developed a method for determining the coefficient of transmissibility from the recovery of the water level in a well that has been bailed. At any given point on the recovery curve the following equation applies:

$$s' = \frac{V}{4\pi T t [e^{r_w^2 S/4Tt}]} \quad (18)$$

where

- $s'$  = residual drawdown,
- $V$  = volume of water removed in one bailer cycle,
- $T$  = coefficient of transmissibility,
- $S$  = coefficient of storage,
- $t$  = length of time since the bailer was removed,
- $r_w$  = effective radius of the well.

The effective radius,  $r_w$ , of the well is very small in comparison to the extent of the aquifer. As  $r_w$  is small, the term in brackets in equation 18 approaches unity as  $t$  increases. Therefore for large values of  $t$ , equation 18 may be modified and rewritten, in consistent units, as

$$s' = \frac{V}{4\pi T t} = \frac{V}{12.57 T t'} \quad (19)$$

where  $s'$ ,  $T$ , and  $t$  have units and significance as previously defined, and where  $V$  represents the volume of water, in gallons, removed during one bailer cycle. If the residual drawdown is observed at some time after completion of  $n$  bailer cycles then the following expression applies:

$$s' = \frac{1}{12.57 T} \left[ \frac{V_1}{t_1} + \frac{V_2}{t_2} + \frac{V_3}{t_3} + \dots + \frac{V_n}{t_n} \right] \quad (20)$$

where the subscripts merely identify each cycle of events in sequence.



Thus  $V_3$  represents the volume of water removed during the third bailer cycle and  $t_3$  is the elapsed time from the instant that water was removed from storage to the instant at which the observation of residual drawdown was made.

If approximately the same volume of water is removed by the bailer during each cycle, then equation 20 becomes

$$s' = \frac{V}{12.57T} \left[ \frac{1}{t_1} + \frac{1}{t_2} + \frac{1}{t_3} + \dots + \frac{1}{t_n} \right] \quad (21)$$

The "bailer" method is thus applied to a single observation of the residual drawdown after the time since bailing stopped becomes large. The transmissibility is computed by substituting in equation 21 the observed residual drawdown, the volume of water  $V$  considered to be the average amount removed by the bailer in each cycle, and the summation of the reciprocal of the elapsed time, in days, between the time each bailer of water was removed from the well and the time of observation of residual drawdown.

#### "SLUG" METHOD

Ferris and Knowles (1954) discuss a convenient method for estimating the coefficient of transmissibility, under certain conditions. This is done by injecting a given quantity or "slug" of water into a well. Their equation for determining the coefficient of transmissibility is the same as the equation derived by Skibitzke for the bailer method, inasmuch as the effects of injecting a slug of water into a well are identical, except for sign, with the effects of bailing out a slug of water. Thus equation 19 has direct application, only  $s'$  now represents residual head, in feet, at the time  $t$ , in days, following injection of  $V$  gallons of water.

As used in the field, this method requires the sudden injection of a known volume of water into a well and the collection thereafter of a rapid series of water-level observations to define the decay of the head that was built up in the well. An arithmetic plot of residual head values versus the reciprocals of the times of observation should produce a straight line whose slope, appropriately substituted in equation 19, permits computation of the transmissibility.

Suggested equipment for use in injecting a slug of water into a well, and for making the rapid series of water-level observations required immediately thereafter, is shown schematically in figure 25.

The duration of a "slug" test is very short, hence the estimated transmissibility determined from the test will be representative only of the water-bearing material close to the well. Serious errors will



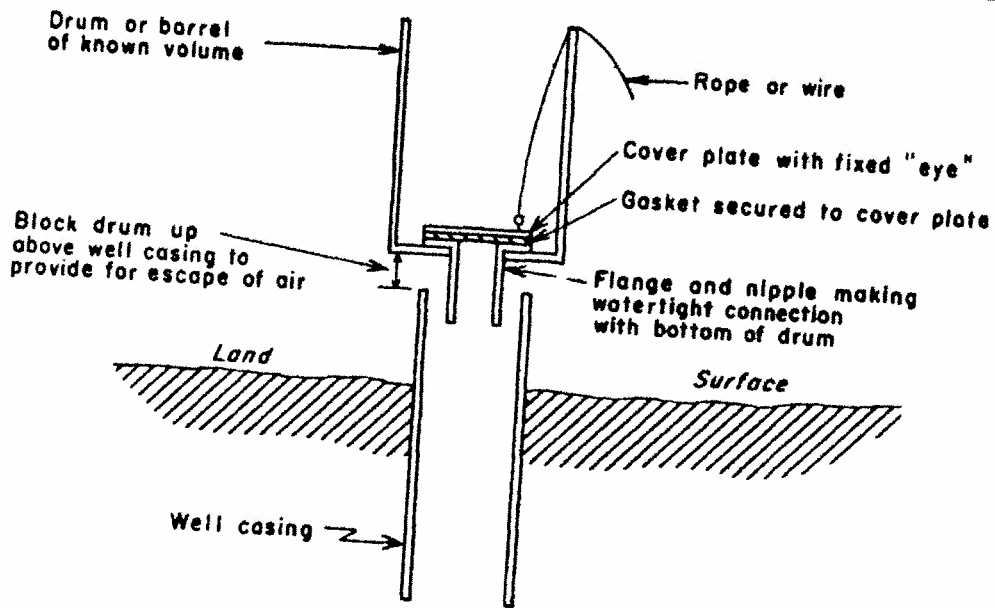

A. APPARATUS FOR MAKING "SLUG" TEST

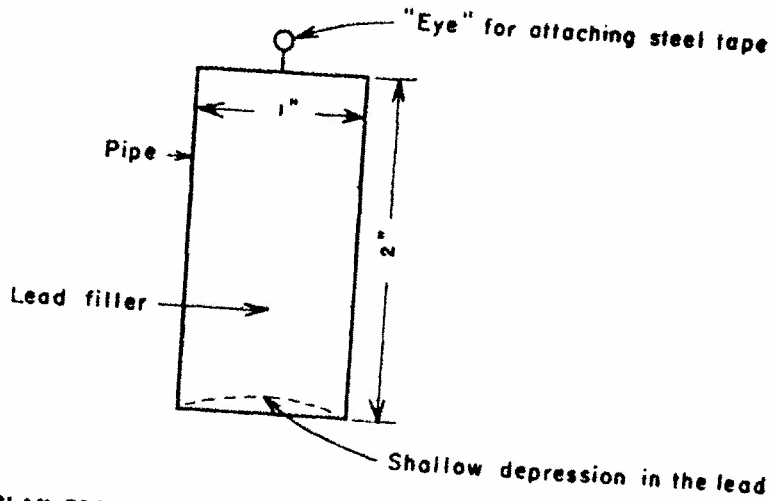

B. PLAN FOR PERCUSSION INSTRUMENT FOR RAPID MEASUREMENT OF WATER LEVELS

FIGURE 25.—Suggested equipment for a "slug" test.

be introduced unless the observation well is fully developed and completely penetrates the aquifer. Use of the "slug" test should probably be restricted to artesian aquifers of small to moderate transmissibility (less than 50,000 gallons per day per foot).

## CONSTANT HEAD WITHOUT VERTICAL LEAKAGE

Controlled pumping tests have proved to be an effective tool in determining the coefficients of storage and transmissibility. In the usual test the discharge rate of the pumped well is held constant, whereas the drawdown varies with time. The resulting data are analyzed graphically as previously described. Jacob and Lohman (1952) derived a formula for determining the coefficients of storage and transmissibility from a test in which the discharge varies with time and the drawdown is held constant. The formula, based on the assumptions that the aquifer is of infinite areal extent, and that the coefficients of transmissibility and storage are constant at all times and all places, is developed from the analogy between the hydrologic conditions in an aquifer and the thermal conditions in an equivalent thermal system. The formula is written as

$$Q = 2\pi T s_w G(\alpha), \quad (22)$$

where

$$G(\alpha) = \frac{4\alpha}{\pi} \int_0^{\infty} x e^{-\alpha x^2} \left[ \frac{\pi}{2} + \tan^{-1} \frac{Y_0(x)}{J_0(x)} \right] dx \quad (23)$$

and

$$\alpha = \frac{Tt}{r_w^2 S} \quad (24)$$

Using the customary Survey units, equations 22 and 24 are rewritten in the form

$$Q = \frac{T s_w G(\alpha)}{229} \quad (25)$$

and

$$\alpha = \frac{0.134 Tt}{r_w^2 S} \quad (26)$$

where  $Q$ ,  $T$ , and  $t$  have the units and meaning previously defined and where

$s_w$  = constant drawdown, in feet, in the discharging well,

$r_w$  = effective radius, in feet, of the discharging well.

The terms  $J_0(x)$  and  $Y_0(x)$  are Bessel functions of zero order of the first and second kinds respectively.

The integration required in equation 23 cannot be accomplished directly so it is necessary to replace the integral with a summation and solve it by numerical methods. In this fashion values of  $G(\alpha)$  for values of  $\alpha$  from  $10^{-4}$  to  $10^{12}$ , have been tabulated by Jacob and Lohman, (1952), and are given herewith in table 3. The term  $G(\alpha)$  is

here designated as the "well function of  $\alpha$ , constant-head situation." This table is used in the same manner as table 2, which gives values of  $W(u)$  versus  $u$ .

It is seen from equations 25 and 26 that if  $Q$  can be measured for several values of  $t$  and if the constant drawdown,  $s_w$ , and the effective radius,  $r_w$ , are known,  $S$  and  $T$  can be determined. It is not possible to determine  $S$  and  $T$  directly, however, since  $T$  occurs both in the argument of the function and as a multiplier of  $G(\alpha)$ . A convenient graphical method, similar to that used in solving the nonequilibrium formula, makes it possible to obtain a simple solution.

The first step in this method is the plotting of a type curve on logarithmic coordinate paper. From table 3, values of  $G(\alpha)$  were plotted against the argument  $\alpha$  to form the type curve shown in figure 26. It is shown in several segments in order that the entire type curve may be plotted on a sheet of convenient size. Rearranging equations 25 and 26 there follows:

$$Q = \frac{T s_w}{229} G(\alpha)$$

or

$$\log Q = \left[ \log \frac{T s_w}{229} \right] + \log G(\alpha), \quad (27)$$

and

$$t = \frac{r_w^2 S}{0.137 T} \alpha$$

or

$$\log t = \left[ \log \frac{r_w^2 S}{0.137 T} \right] + \log \alpha \quad (28)$$

If the drawdown,  $s_w$ , is held constant, the bracketed parts of equations 27 and 28 are constant for any given test and  $\log G(\alpha)$  is related to  $\log \alpha$  in the same manner that  $\log Q$  is related to  $\log t$ . (Note the similarity in form between equations 27 and 28 and equations 9a and 10a.) Therefore if values of the discharge,  $Q$ , are plotted against corresponding values of time,  $t$ , on logarithmic tracing paper to the same scale as the type curve, the curve of observed data will be similar to the type curve. The data curve may then be superposed on the type curve, the coordinated axes of the two curves being held parallel, and translated to a position that represents the best fit of the data to the type curve. An arbitrary point is selected on the overlapping portion of the sheets and the coordinates of this common point on both sheets are used with equations 25 and 26 to solve for  $T$  and  $S$ . This graphical solution is similar to that used with the Theis nonequilibrium formula.

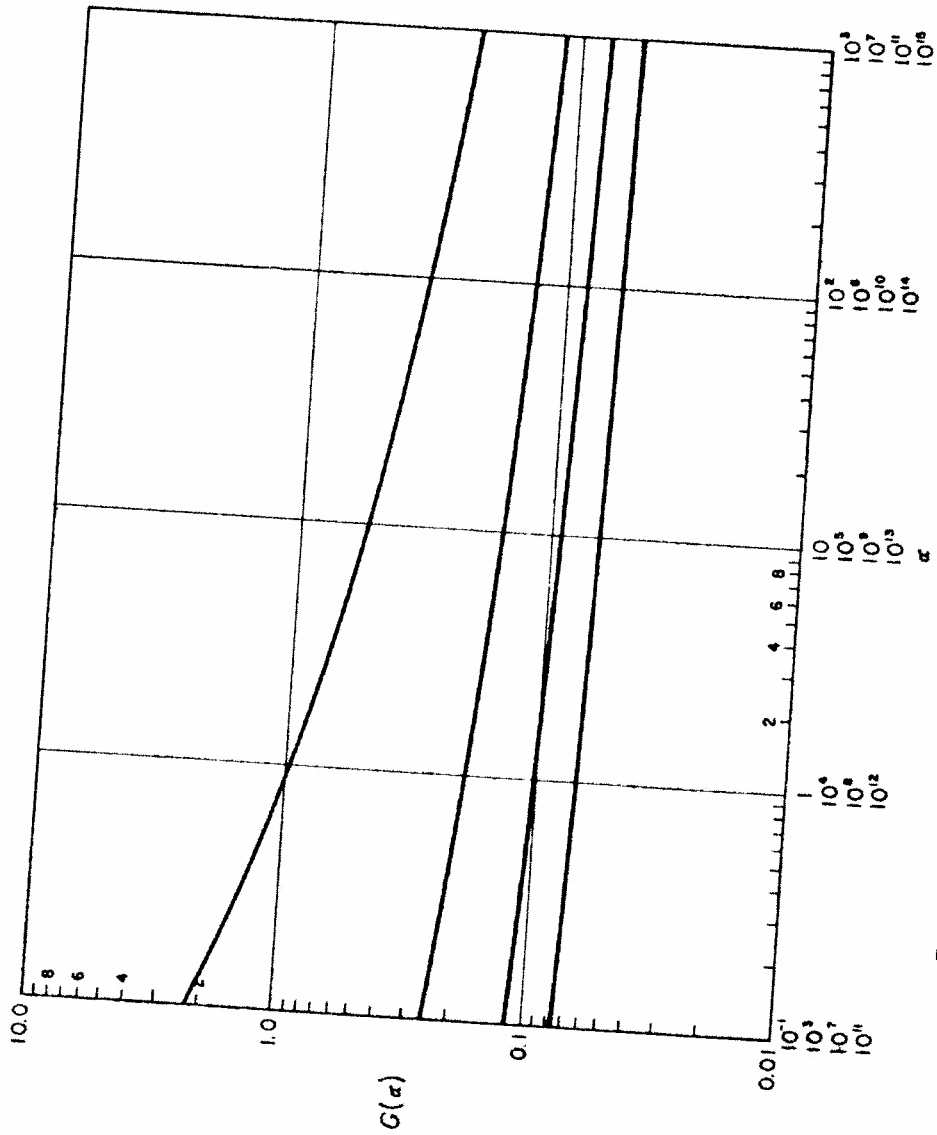

FIGURE 26.—Logarithmic graph of well function  $G(u)$ —constant drawdown.

TABLE 3.—Values of  $G(\alpha)$  for values of  $\alpha$  between  $10^{-4}$  and  $10^{12}$

[From Jacob and Lohman, 1952, p. 561]

	$10^{-4}$	$10^{-3}$	$10^{-2}$	$10^{-1}$	1	10	$10^2$	$10^3$
1	56.9	18.34	6.13	2.249	0.985	0.534	0.346	0.251
2	40.4	13.11	4.47	1.716	.803	.461	.311	.232
3	33.1	10.79	3.74	1.477	.719	.427	.294	.222
4	28.7	9.41	3.30	1.333	.667	.406	.283	.215
5	25.7	8.47	3.00	1.234	.630	.389	.274	.210
6	23.5	7.77	2.78	1.160	.602	.377	.268	.206
7	21.8	7.23	2.60	1.103	.580	.367	.263	.203
8	20.4	6.79	2.46	1.067	.562	.359	.258	.200
9	19.3	6.43	2.35	1.018	.547	.352	.254	.198
10	18.3	6.13	2.26	.965	.534	.346	.251	.196

	$10^4$	$10^5$	$10^6$	$10^7$	$10^8$	$10^9$	$10^{10}$	$10^{11}$
1	0.1004	0.1008	0.1000	0.1177	0.1037	0.0927	0.0838	0.0764
2	.1841	.1524	.1290	.1131	.1002	.0899	.0814	.0744
3	.1777	.1479	.1266	.1106	.0952	.0853	.0801	.0733
4	.1733	.1449	.1244	.1080	.0908	.0812	.0762	.0726
5	.1701	.1426	.1227	.1076	.0898	.0804	.0756	.0720
6	.1676	.1406	.1213	.1066	.0888	.0794	.0747	.0716
7	.1654	.1386	.1202	.1057	.0880	.0786	.0740	.0712
8	.1636	.1380	.1192	.1049	.0873	.0779	.0734	.0709
9	.1621	.1369	.1184	.1043	.0867	.0772	.0728	.0706
10	.1608	.1360	.1177	.1037	.0862	.0767	.0724	.0704

Jacob and Lohman (1952) showed that for large values of  $t$ , the function  $G(\alpha)$  can be replaced by  $2/W(u)$ , and it has already been shown (see discussion, p. 99) that the approximate form of  $W(u)$  is given by  $2.30 \log_{10} (2.25Tt/Sr_w^2)$ . Making this substitution for  $G(\alpha)$  in equation 22, there follows

$$Q = \frac{4\pi T s_w / 2.30}{\log_{10} (2.25Tt/r_w^2 S)}$$

or, rearranging terms,

$$\frac{s_w}{Q} = \frac{2.30}{4\pi T} \log \frac{t}{r_w^2} + \frac{2.30}{4\pi T} \log \frac{2.25T}{S} \tag{29}$$

It should be evident from the form of equation 29, that if arithmetic values of the variable  $s_w/Q$  are plotted against logarithmic values of the variable  $t/r_w^2$  the points will define a straight line. The slope of this line, in equation 29, is the prefix of the variable term  $\log (t/r_w^2)$ . In other words,

$$\text{Slope of straight-line plot} = \frac{\Delta(s_w/Q)}{\Delta \log (t/r_w^2)} = \frac{2.30}{4\pi T}$$

Once the slope of the graph is determined, therefore, the coefficient of transmissibility may be computed from the relation

$$T = \frac{2.30 \Delta(\log t/r_w^2)}{4\pi \Delta(s_w/Q)} \tag{30}$$

If the slope is measured over one log cycle then the term  $\Delta \log (t/r_w^2)$  equals unity and equation 30 is further simplified to the form

$$T = \frac{2.30}{4\pi\Delta(s_w/Q)} \quad (31)$$

The coefficient of storage could then be found by substituting in equation 29 the computed value of  $T$  and the coordinates of any convenient point on the straight-line plot. However, the computation is greatly simplified by noting that for the point where the straight-line plot intersects the logarithmic time axis (that is, where  $s_w/Q=0$ ), equation 29 becomes

$$S = 2.25T(t/r_w^2)_0 \quad (32)$$

In the usual Survey units, equations 31 and 32 are written

$$T = \frac{264}{\Delta(s_w/Q)} \quad (33)$$

and

$$S = 0.3T(t/r_w^2)_0 \quad (34)$$

Thus equations 33 and 34 are applied through the simple device of a semilogarithmic plot where values of  $s_w/Q$  are plotted on the arithmetic scale against corresponding values of  $t/r_w^2$  on the logarithmic scale.

The methods that have been outlined in this section are useful in determining the coefficient of transmissibility but should be used with caution in determining the coefficient of storage because it is often difficult to determine the effective radius of the pumped well.

#### CONSTANT DISCHARGE WITH VERTICAL LEAKAGE "LEAKY AQUIFER" FORMULA

A problem of practical interest is that of an elastic artesian aquifer that is replenished by vertical leakage through overlying or underlying semipermeable confining beds. In most places the confining beds only impede or retard the movement of ground water rather than prevent it. It is often true that this retardation of ground-water movement is sufficient so that the Theis equation (which assumes impermeable confining beds) can be applied. Nevertheless there will be occasions when departure of the test data from the predictions of the Theis equation will require investigation of the ability of the confining beds to transmit water.

As an example of the magnitude of flow through material of low permeability, consider a semipermeable confining bed, 50 feet thick, consisting of silty clay that has a permeability of 0.2 gallon per day per square foot. Such a material is listed by Wenzel (1942, p. 13,

lab. no. 2,278) as including about 49 percent (by weight) clay and about 45 percent silt. Assume that the confining bed is saturated and that in some manner there is established and maintained a head differential of 25 feet between the top and bottom surfaces of the bed. The rate of percolation, related to this head differential, through the confining bed is computed from the previously given (see p. 73) variant of Darcy's law,

$$Q_c = P'IA,$$

where, in this example,

$Q_c$  = discharge in gallons per day through specified area of confining bed,

$P'$  = vertical permeability of confining bed = 0.2 gallon per day per square foot,

$I$  = hydraulic gradient imposed on confining bed =  $25/50 = 0.5$  foot per foot.

$A$  = specified area of confining bed through which percolation occurs.

Thus, through a confining-bed area of one square foot,

$$Q_c = 0.2 \times 0.5 \times 1 = 0.1 \text{ gallon per day,}$$

or, through a confining-bed area of one square mile,

$$Q_c = 0.2 \times 0.5 \times 5,280 \times 5,280 = 2,800,000 \text{ gallons per day.}$$

It is known that the cone of depression created by pumping a well in an artesian aquifer grows rapidly and thus in a relatively short time encompasses a large area. As shown by the above computations, the total amount of vertical seepage through confining beds may be quite large, even though the permeability of these formations is relatively small. If the confining bed in turn is overlain by an aquifer of appreciable storage and transmitting capacity, the radius of the cone of influence developed by a well pumping from the artesian aquifer will be determined by the hydrologic regimen of the artesian aquifer, the confining bed, and the leakage-source aquifer.

The first detailed analysis and solution of the leaky-aquifer problem was developed by DeGlee<sup>1</sup> (1930) and later supplemented by Steggenz and Van Nes (1939).

In these analyses, assumptions related to the physical flow system are: (a) the artesian aquifer is bounded above or below by a semi-permeable confining bed, (b) the aquifer, when pumped is supplied by leakage through the confining bed, the leakage being proportional to the drawdown, and (c) the aquifer and confining bed are independently homogeneous and isotropic. It is also assumed that the water level in the aquifer supplying water to the semipermeable bed is maintained

<sup>1</sup> Glee, G. J. de, 1930, over grondwaterstromingen bij wateronttrekking door middel van putten [On ground-water currents through draining by means of wells]: Delft (Netherlands) Tech. Hogeschool thesis.

at or very near static level through the interval of pumping. The solution developed is for the steady-state condition, wherein it is assumed that the drawdown is zero at  $r = \infty$ .

Jacob (1946) also analyzed this problem, verifying the solution for steady flow and also developing a solution for the transient state. His final steady-state equation, in nondimensional form, for the drawdown in an infinite artesian aquifer has the form

$$s = \frac{Q}{2\pi T} K_0(x) \quad (35)$$

or, in the usual Survey units,

$$s = \frac{229 Q K_0(x)}{T}, \quad (36)$$

where

$$x = \frac{br}{a} \quad (37)$$

and

$$a = \sqrt{T/S}$$

$$b = \sqrt{P/m'S}$$

$T$  = coefficient of transmissibility of the artesian aquifer in gallons per day per foot,

$P'$  = coefficient of vertical permeability of the semipermeable confining bed, in gallons per day per square foot,

$S$  = coefficient of storage of the artesian aquifer,

$Q$  = rate of withdrawal by the pumped well, in gallons per minute,

$m'$  = thickness of the semipermeable confining bed, in feet,

$r$  = distance from the pumped well to the observation well, in feet,

$s$  = drawdown in the observation well, in feet.

The symbol  $K_0(x)$  is a notation widely but not universally used to identify the modified Bessel function of the second kind of the zero order. In order to avoid any misunderstanding of its present usage it is identified as follows:

$$K_0(x) = -[0.5772 + \log_e (x/2)] I_0(x)$$

$$+ (1/1!)^2 (x/2)^2 + (1/2!)^2 (x/2)^4 (1 + 1/2)$$

$$+ (1/3!)^2 (x/2)^6 (1 + 1/2 + 1/3 + \dots), \quad (38)$$



where

$$I_0(x) = 1 + (x/2)^2/(1!)^2 + (x/2)^4/(2!)^2 + (x/2)^6/(3!)^2 + \dots \quad (39)$$

The notation  $I_0(x)$  is used to represent the modified Bessel function of the first kind of zero order. Values of the function  $K_0(x)$  over the range of interest for most ground-water problems are given in table 4.

Equations 36 and 37 may be rewritten in the following form:

$$\log s = \log \left[ \frac{229 Q}{T} \right] + \log K_0(x) \quad (40)$$

$$\log r = \log \left[ \frac{a}{b} \right] + \log x \quad (41)$$

The bracketed portions of equations 40 and 41 include all the terms that have been assumed constant in the derivation. It follows then that the variable  $s$  is related to  $r$  in the same manner that  $K_0(x)$  is related to  $x$ . Thus the form of equations 40 and 41 once again suggests the same convenient method of graphical solution that has already been described for resolving the Theis formula. A type curve for use in solving equations 36 and 37 is prepared by plotting on logarithmic graph paper the values given in table 4. In figure 27 curve AA is in part a duplication of the lower part of curve BB and in part an extension of that curve into the next lower log cycle.

The solution of equations 36 and 37 thus requires plotting the field observations of  $s$  and  $r$ , at some particular time  $t$ , on logarithmic graph paper, using the same size of logarithmic scale adopted for the type curve. The data curve is superposed on the type curve, the coordinate axes of the two curves being held parallel, and translated to the position that represents the best fit of the field data to the type curve. When the match position is found, the amount of shift or translation from the  $s$  scale to the  $K_0(x)$  scale is measured by the bracketed term of equation 40, and the translation between the  $r$  scale and the  $x$  scale is represented by the bracketed member of equation 41. An arbitrary point is selected on the data curve and the coordinates of this common point on both the data curve and the type curve are recorded. These coordinates, when substituted in equations 36 and 37, permit computation of the coefficient of transmissibility,  $T$ , of the artesian bed, and the value of  $x$ , which has inherent in it the coefficient of vertical permeability of the leaky confining bed.

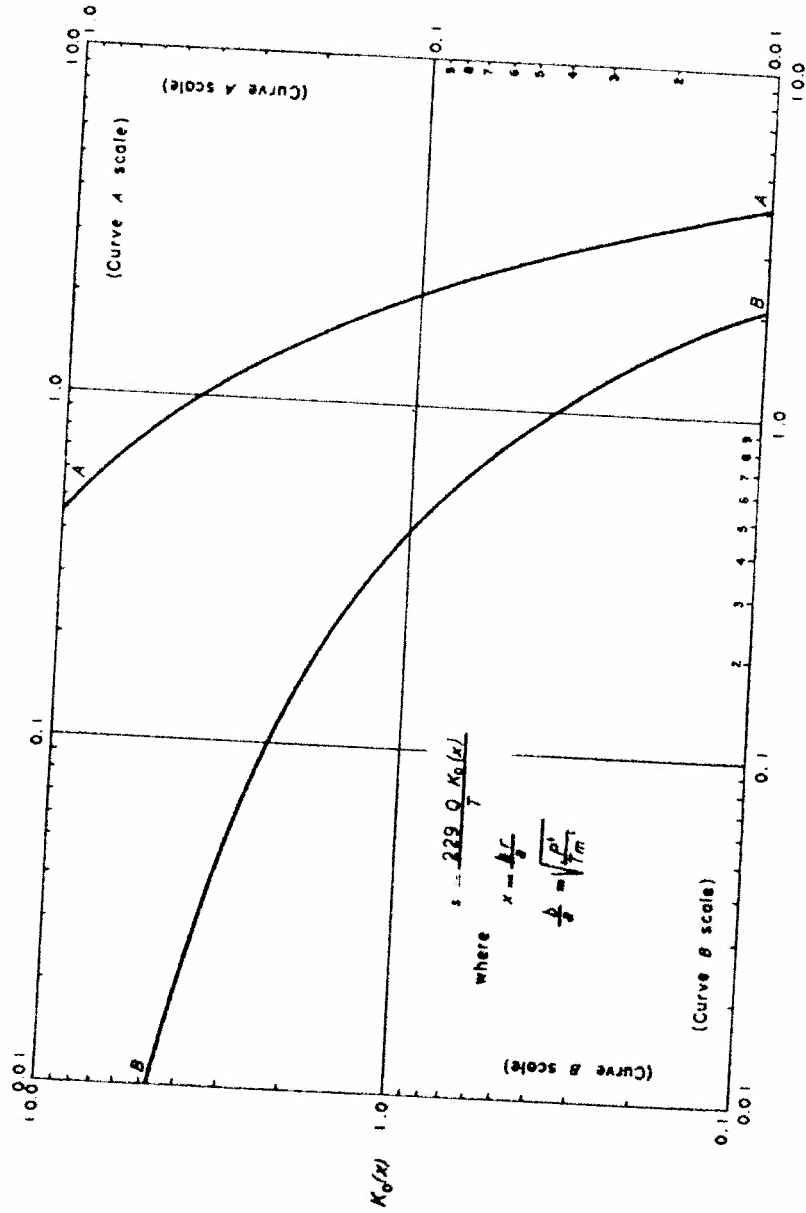

FIGURE 27.—Logarithmic graph of the modified Bessel function  $K_0(x)$ .



Hantush and Jacob (1955) have described in considerable detail their development of equations for the nonsteady-state solution to the foregoing problem.

The preceding discussion has stipulated that equations 36, 37, and 42 are properly applied only to steady-state conditions. This means that enough time must have elapsed for the drawdown to have stabilized throughout the region for which the plot of  $s$  versus  $r$  is to be made. The manner in which the drawdown stabilizes at observation points at selected distances from the discharging well is shown on a semilogarithmic plot by Hantush and Jacob (1955, fig. 1). In effect their plot shows individual time-drawdown curves because values of drawdown divided by a constant are plotted against values of the logarithm of time multiplied by a constant. Of special interest is the fact that for all the curves, regardless of the represented distance from the discharging well, the drawdown stabilizes or levels off at the same value of time.

Assuming, therefore, that the requirement of stabilized drawdown has been met, an important feature of the logarithmic type curve (fig. 27) should be recognized. Note that the curve is drawn only for values of  $x$  greater than 0.01. Thus the matching of a logarithmic plot of  $s$  versus  $r$  against the leaky-aquifer type curve is appropriate only if the observed data and computed results can be shown to yield values of  $x$  (which is directly related to  $r$ ) that are greater than 0.01. Actually the critical value of  $x$  is about 0.03, as can be demonstrated in the following manner.

In the tables of the Bessel functions (U.S. Department of Commerce, 1952) the following relation applies for small values of  $x$ :

$$K_0(x) = E_0(x) + F_0(x) \log_{10}(x).$$

The tables show that for values of  $x$  ranging from 0 to about 0.03 the values of  $E_0(x)$  and  $F_0(x)$  are 0.116 and  $-2.303$  respectively. Substituting these equivalents in the above relation yields

$$K_0(x) = 0.116 - 2.303 \log_{10}(x),$$

which, by substitution from equation 37 and conversion to the natural logarithm, becomes

$$K_0(x) = 0.116 - \log_e(br/a).$$

If equation 35 is rewritten in terms of the difference in drawdown between two points at radii  $r_1$  and  $r_2$  (where  $r_2 > r_1$ ) on the cone of

depression, and the foregoing relation for  $K_0(x)$  substituted therein, there follows the expression

$$s_1 - s_2 = \frac{Q}{2\pi T} \left[ \left( 0.116 - \log_e \frac{br_1}{a} \right) - \left( 0.116 - \log_e \frac{br_2}{a} \right) \right],$$

or

$$s_1 - s_2 = \frac{Q}{2\pi T} \log_e \frac{r_2}{r_1},$$

which is the familiar Thiem equilibrium formula previously presented in the form of equation 1. The conclusion to be drawn is that in the region  $x < 0.03$  a logarithmic plot of  $s$  versus  $r$  exhibits only the effects of radial flow through the aquifer toward the discharging well; the leakage effects are not significant enough to influence the shape of the curve. Although the leaky-aquifer type curve could be extended readily into this region of low  $x$  values, its curvature is insensitive to leakage and is too slight to permit a matching that would be definitive of the  $x$  value needed for computing the leakage coefficient.

The nature of the abbreviated relation for  $K_0(x)$ , presented in the preceding discussion, suggests a simple means for analyzing the steady-state drawdown data within the region  $x < 0.03$ . Rewriting equation 35 in terms of this special relation for  $K_0(x)$  produces

$$s = \frac{Q}{2\pi T} [0.116 - \log_e (br/a)],$$

or, in the usual Survey units and the common logarithm,

$$s = \frac{229Q}{T} \left( 0.116 - 2.303 \log_{10} \frac{br}{a} \right). \quad (43)$$

Recognizing that  $s$  and  $r$  are the only variables in equation 43, obviously a semilogarithmic plot of  $s$  versus  $\log r$  produces a straight line. If  $r_0$  is the intercept of this straight line at the zero-drawdown axis, appropriate substitution in equation 43 yields

$$\log_{10} \frac{br_0}{a} = \frac{0.116}{2.303},$$

or

$$\frac{b}{a} = \frac{1.12}{r_0} \quad (43a)$$

The analysis of steady-state test data for a leaky aquifer can thus be summarized in the following three simple procedures:

1. Select for plotting only the drawdown data which are within the region where drawdowns have levelled off.
2. Use equations 36, 37, and 42 with a logarithmic plot of  $s$  versus  $r$ , matched to the leaky-aquifer type curve (fig. 27), only if the observed data and resulting computations produce values of  $x$  greater than 0.03.
3. Use equations 2, 4, and 43a with a semilogarithmic plot of  $s$  versus  $\log r$  if the data and resulting computations produce values of  $x$  less than 0.03.

The earliest observations of drawdown in each observation well, when  $s$  is small, should conform to the Theis nonequilibrium type curve for the infinite (nonleaky) aquifer if the rate of leakage from the confining bed is comparatively small. The coefficient of storage for the artesian aquifer can be determined under these conditions from the earliest observations of drawdown (Jacob, 1946, p. 204). The computed coefficient of transmissibility should be checked by comparing the value obtained from matching the earliest data to the nonequilibrium type curve with the value obtained by matching the later data to the steady-state leaky-aquifer type curve. If consistency of the  $T$  values is not obtained, then the leakage may be causing too much deviation at the smaller values of  $t$  to permit application of the Theis nonequilibrium formula.

#### VARIABLE DISCHARGE WITHOUT VERTICAL LEAKAGE

By R. W. STALLMAN

##### CONTINUOUSLY VARYING DISCHARGE

The rate at which water is pumped from a well or well field commonly varies with time in response to seasonal changes in demand. For instance, the pumping rate, as shown by records of daily or monthly discharge, is often found to be varying continuously. Where this element of variability is recognized in ground-water problems, the analytical methods that are described in the preceding sections of this report are not applicable without some modification or approximation. Exact equations could perhaps be developed for the case of continuously varying discharge, but the cost of analysis, in terms of time and effort, would likely be prohibitive considering that a separate and specific solution would be required for each problem. It is considered more expedient, therefore, to utilize the existing analytical methods, rendering them applicable to the field situation by introducing tolerable approximations of the field conditions. As an example, consider a situation where the pumping rate in a well (which may also represent a well field) tapping an artesian aquifer varies continuously with time in the manner indicated by the smooth curve shown in

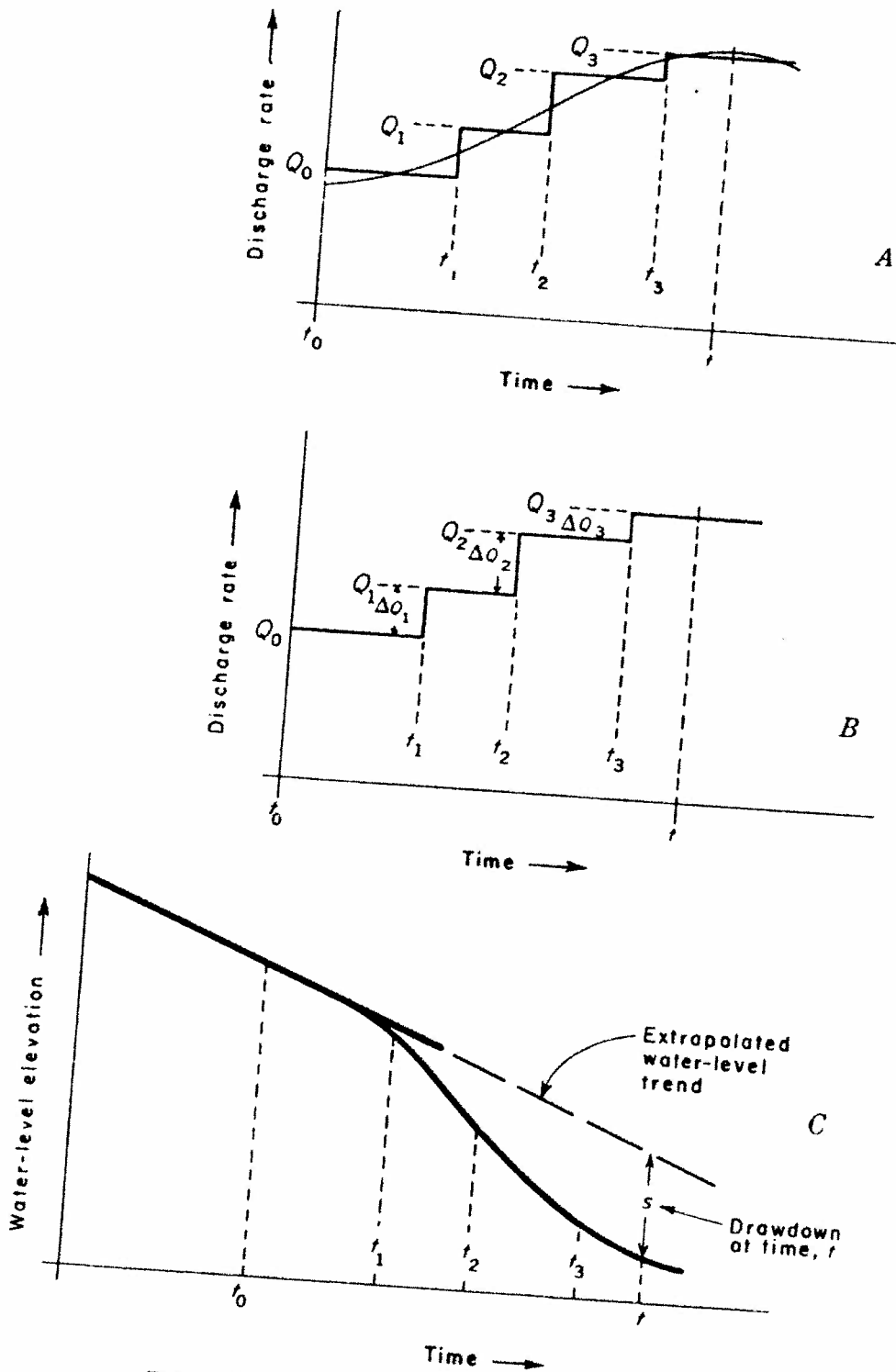

FIGURE 28.—Nomenclature for continuously varying discharge.

figure 28A. This smooth curve may be approximated by the series of steps shown, and the analysis of each step may be undertaken starting with conventional theory and equations. Thus the Theis

nonequilibrium formula (eq. 6) can be used to construct a type curve for analyzing the observed drawdowns caused by the stepped pumping rates indicated in figure 28A and B. The drawdown,  $s$ , at distance  $r$  from the pumped well, at any time  $t$ , is

$$s = s_1 + s_2 + s_3 \dots \dots \dots + s_n \quad (44)$$

where the subscripts refer to the  $\Delta Q$  values of figure 28B. The zero reference time  $t_0$  is chosen arbitrarily so that the effects of the antecedent rate of pumping,  $Q_0$ , are established as a regular trend that can be projected or extrapolated with certainty, as shown in figure 28C, over the time span occupied by the stepped pumping rates. Applying the Theis nonequilibrium formula to define each of the drawdown components given in equation 44, there follows,

$$s = \frac{114.6}{T} [\Delta Q_1 W(u)_1 + \Delta Q_2 W(u)_2 + \Delta Q_3 W(u)_3 \dots \dots \dots + \Delta Q_n W(u)_n]. \quad (45)$$

The corresponding  $u$  values are

$$u_1 = \frac{1.87r^2S}{T(t-t_1)}; u_2 = \frac{1.87r^2S}{T(t-t_2)}; u_3 = \frac{1.87r^2S}{T(t-t_3)}; \dots; u_n = \frac{1.87r^2S}{T(t-t_n)}. \quad (46)$$

Therefore,

$$u_2 = u_1 \left[ \frac{t-t_1}{t-t_2} \right]; u_3 = u_1 \left[ \frac{t-t_1}{t-t_3} \right]; \dots \dots \dots; u_n = u_1 \left[ \frac{t-t_1}{t-t_n} \right]. \quad (47)$$

Inspection of equations 46 and 47 should indicate that virtually an infinite number of type curves can be constructed for solving equation 45. For practical purposes, however, only a family of curves need be constructed.

It can be seen from equations 46 that the relation between the  $u$  values is dependent on the value of  $t$  selected. For any given value of  $t$ , the values of  $u$  are proportional to the constant  $1.87r^2S/T$ . Therefore the family of curves must be constructed using  $t$  and  $1.87r^2S/T$  as independent variables and  $\sum_1^n \Delta QW(u)$  as the dependent variable. This is accomplished by first assuming several values of  $1.87r^2S/T$  for a particular value of  $t$ . Values of  $u_1$  are then computed for that  $t$  for the assumed values of  $1.87r^2S/T$  using the first of equations 46. Equations 47 are then used to compute values of  $u_2, u_3 \dots u_n$  for each assumed value of  $1.87r^2S/T$ . These in turn determine (see table 2) the corresponding  $W(u)$  values, which are used to compute the quantity in brackets (the sum of all the  $\Delta QW(u)$  terms) in equation 45. Thus a set of values is produced for the sum



of the  $\Delta QW(u)$  terms, corresponding with the assumed values of  $1.87r^2S/T$  and all are related to one assumed value of  $t$ . This computing procedure is repeated for each value of  $t$  in a whole set of  $t$  values selected to span a time range that will permit drawing the family of type curves, shown schematically in figure 29, through the same time

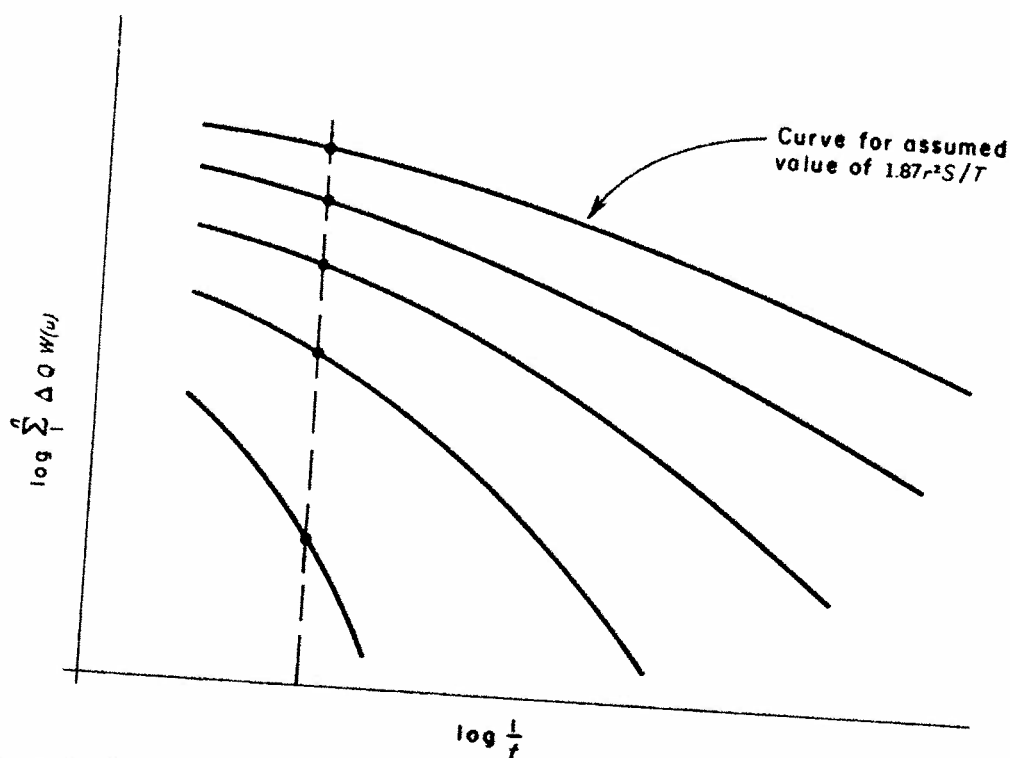

FIGURE 29.—Schematic plot of family of type curves for problems involving continuously varying discharge.

interval covered by the drawdown observations in the aquifer. The field-data plot of  $\log s$  versus  $\log 1/t$  is superposed on the family of type curves, taking care that the logarithmic time scales of the two graphs are exactly matched. The data plot is then shifted along the  $\sum_1^n \Delta QW(u)$  axis until the position is found where the curvature of the data plot is identical with an underlying type curve or with an interpolated type curve position. It follows that this serves to identify the data curve with a specific value of  $1.87r^2S/T$ . Values of  $s$  and  $\sum_1^n \Delta QW(u)$  are read from a point common to both graphs and entered in equation 45 to solve for  $T$ . The computed value of  $T$  can then be used with the value of  $1.87r^2S/T$  to solve for  $S$ . Should several observation wells at different radii be available, it may be more convenient to construct a type curve suitable for matching with the observed drawdown profile. For a selected observation time, values

of  $\sum_1^n \Delta QW(u)$  and  $1.87r^2S/T$  are taken from figure 29 and used to construct a new type curve by plotting  $\log \sum_1^n \Delta QW(u)$  against  $\log (1.87r^2S/T)$ . This new logarithmic type curve, drawn for a selected time,  $t$ , can be matched with a logarithmic data plot of  $s$  versus  $r^2$ , drawn for the same time  $t$ .

#### INTERMITTENT OR CYCLIC DISCHARGE

Analysis of drawdown data by means of the methods described in the preceding section is likely to require a large amount of calculation. However, for certain specific kinds of discharge variations the analysis can be simplified considerably. The detailed solutions of two specific cases have been described by Theis and Brown (1954). One of the problems solved was that of computing the drawdown occurring in a well being operated in a regular cycle of pumping at a constant rate for a given time interval, then resting for a given time interval. Their final equation, in the usual Survey units, for drawdown in the pumped well after  $n$  cycles of operation is

$$s_n = \frac{264Q}{T} \log_{10} \frac{1 \cdot 2 \cdot 3 \cdot \dots \cdot n}{(1-p)(2-p)(3-p) \dots (n-p)}, \quad (48)$$

where  $p$  is the fractional part of the cycle during which the well is pumped. In part, the simple form of equation 48 was obtained by utilizing the semilog approximation (eq. 4) of the Theis nonequilibrium formula. Many regular operational cycles are easily generalized and analysis may lead to a final expression comparable, in simplicity, to equation 48.

#### CHANNEL METHODS—LINE SINK OR LINE SOURCE

##### CONSTANT DISCHARGE

##### NONSTEADY STATE, NO RECHARGE

As early as 1938 Theis (Wenzel and Sand, 1942, p. 45) had developed a formula for determining the decline in artesian head at any distance from a drain discharging water at a uniform rate. In 1949 Ferris (1950) derived a formula that can be shown to be identical with the one derived by Theis. The development is based on the following assumptions: (a) the aquifer is homogeneous, isotropic, and of semi-infinite (bounded on one side only by the stream) areal extent; (b) the discharging drain completely penetrates the aquifer; (c) the aquifer is bounded by impermeable strata above and below; (d) the flow is laminar and unidimensional; (e) the release of water from storage is instantaneous and in proportion to the decline in head; and (f) the drain discharges water at a constant rate.

Slightly modifying the form used by Ferris, the drain formula can be written nondimensionally, as

$$s = \frac{Q_0 x}{2T} \left[ \frac{e^{-u^2}}{u\sqrt{\pi}} - 1 + \frac{2}{\sqrt{\pi}} \int_0^{\frac{x}{2\sqrt{Tt}S}} e^{-u^2} du \right], \quad (49)$$

where

$$u = x \sqrt{\frac{S}{4Tt}},$$

or

$$u^2 = \frac{x^2 S}{4Tt}. \quad (50)$$

Ferris suggested that the quantity in brackets be written symbolically, for convenience, as  $D(u)$  which is to be read "drain function of  $u$ ," and in this report the subscript  $q$  will identify it with the constant discharge situation. Equations 49 and 50 can therefore be rewritten in abbreviated form, in the usual Survey units, as

$$s = \frac{720 Q_0 x}{T} D(u)_q, \quad (51)$$

and

$$u^2 = \frac{1.87 x^2 S}{Tt}, \quad (52)$$

where

- $s$  = drawdown, in feet, at any point in the vicinity of the drain discharging at a constant rate,
- $Q_0$  = constant discharge (that is, base flow) of the drain, in gallons per minute per lineal foot of drain,
- $x$  = distance, in feet, from the drain to the point of observation,
- $t$  = time, in days, since the drain began discharging,
- and  $S$  and  $T$  have the meaning and units already defined.

From inspection of equations 51 and 52 it follows that if  $s$  can be measured at several values of  $t$ , and if  $x$  and  $Q_0$  are known, then  $S$  and  $T$  can be determined. However, the occurrence of two unknowns and the nature of the drain function make an exact analytical solution impossible and trial solution most laborious. A graphical solution of superposition, similar to the one devised by Theis for solution of his nonequilibrium formula, affords a simple solution of equation 51.

The first step in constructing the type curve is to assume values of  $u$  and compute the corresponding values for  $D(u)_q$  from equation 49, which can be done easily with the aid of published tables (U.S. Natl. Bur. of Standards, 1954). Values of  $D(u)_q$  and  $u^2$  for values of  $u$  from 0.0510 to 1.0000 are given in table 5. These data are then used

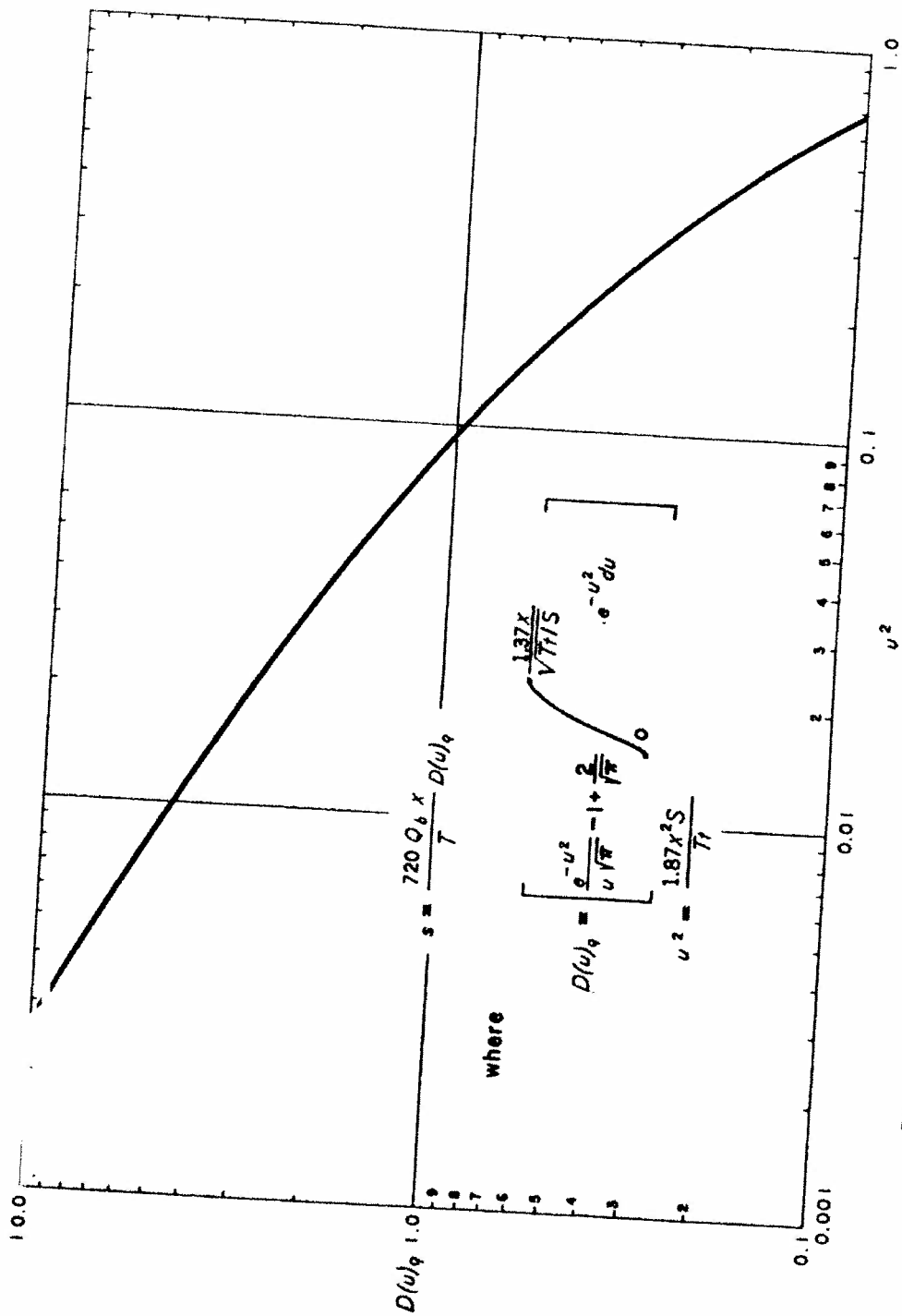

FIGURE 30.—Logarithmic graph of the drain function  $D(u)_q$  for channel method—constant discharge.

to prepare a type curve on logarithmic coordinate paper by plotting values of  $u$  or  $u^2$  against values of  $D(u)_e$ . Such a type curve is shown in figure 30 and, for convenience in subsequent computation, values of  $D(u)_e$  have been plotted against values of  $u^2$ .

Rearranging equations 51 and 52 and taking the log of both sides, there follows:

$$\log s = \left[ \log \frac{720 Q_e x}{T} \right] + \log D(u)_e, \tag{53}$$

and

$$\log \frac{x^2}{t} = \left[ \log \frac{T}{1.87 S} \right] + \log u^2. \tag{54}$$

For a given test, the bracketed parts of equations 53 and 54 are constant and  $\log D(u)_e$  is related to  $\log u^2$  in the manner that  $\log s$  is related to  $\log (x^2/t)$ . Therefore, if values of the drawdown,  $s$ , are plotted versus  $x^2/t$  on logarithmic tracing paper having the same log scale as the type curve for the drain formula, the curve of observed data will be similar to the type curve. The data curve may thus be superposed on the type curve, with the coordinate axes held parallel, and translated to the position where the observed data coincide or make the best fit with the type curve. When this matching position has been found, an arbitrary point is selected, common to both curves, and the coordinates of this common point are used to solve equations 53 and 54 for  $T$  and  $S$ .

TABLE 5.—Values of  $D(u)_e$ ,  $u$ , and  $u^2$  for channel method—constant discharge formula.<sup>a</sup>

[Data for plotting type curve (fig. 30) for equation 51. After Ferris (1950)]

$u$	$u^2$	$D(u)_e$	$u$	$u^2$	$D(u)_e$
0.0510	0.0026	10.091	.2648	.070	1.280
.0600	.0036	8.437	.3000	.090	1.047
.0700	.0049	7.099	.3317	.110	.8847
.0900	.0064	6.097	.3605	.130	.7641
.0900	.0081	5.319	.4000	.160	.6303
.1000	.010	4.698	.4359	.190	.5327
.1140	.013	4.013	.4796	.230	.4370
.1265	.016	3.531	.5291	.280	.3516
.1414	.020	3.069	.5745	.330	.2895
.1581	.025	2.657	.6164	.380	.2426
.1732	.030	2.355	.6633	.440	.1996
.1871	.035	2.120	.7071	.500	.1666
.2000	.040	1.933	.7616	.580	.1333
.2236	.050	1.648	.8124	.660	.1084
.2449	.060	1.440	.8718	.760	.08503
			.9487	.900	.06207
			1.0000	1.000	.05026

Despite the restrictive assumptions upon which it is based, the drain formula, as it has been called, has been applied successfully in determining the coefficients of transmissibility and storage of an aquifer and in estimating the pickup by or leakage from drains.

Discussion and comparison of various ways of plotting the type curves for the drain function  $D(u)$ , and the well function  $W(u)$  (see figures 30 and 23) are given by Warren (1952, written communication).

#### CONSTANT HEAD

#### UNSTEADY STATE, NO RECHARGE

By R. W. STALLMAN

The decline in artesian head at any distance from a stream or drain, whose course may be approximated by an infinite straight line, subsequent to a sudden change in stream stage, can be found by borrowing the solution to an analogous heat-flow problem (Ingersoll, Zobel, and Ingersoll, 1948, p. 88). It is assumed that (a) the stream occurs along an infinite straight line and fully penetrates the artesian aquifer; (b) the aquifer is semi-infinite in extent (bounded on one side only by the stream); (c) the head in the stream is abruptly changed from zero to  $s_0$  at time  $t=0$ ; (d) the direction of ground-water flow is perpendicular to the direction of the stream; and (e) the change in the rate of discharge from the aquifer is derived from changes in storage by the heat-flow equation, the distribution of drawdown in the artesian aquifer is found to be

$$s_0 - s = \frac{2s_0}{\sqrt{\pi}} \int_0^{\frac{x}{2\sqrt{TyS}}} e^{-u^2} du,$$

or

$$s = s_0 \left[ 1 - \frac{2}{\sqrt{\pi}} \int_0^{\frac{x}{2\sqrt{TyS}}} e^{-u^2} du \right] = s_0 D(u), \quad (55)$$

where  $D(u)$  replaces the quantity in brackets and represents the drain function of  $u$  for the constant head situation, and where

$$u^2 = \frac{x^2 S}{4Tt}. \quad (56)$$

In the foregoing expressions  $x$  is the distance from the stream or drain to the point at which the decline in artesian head,  $s$ , is observed or known, and  $s_0$  is the abrupt change in stream stage at  $t=0$ . Other symbols are as previously defined. (Note: In equation 55 the integral expression and its coefficient constitute what mathematicians have labelled the error function, written as "erf." The bracketed portion of equation 55 is identified as the complementary error function, written as "erfc".)

The relation expressing the discharge from the aquifer, per unit length of stream channel,  $Q$ , resulting from the change in stream stage,

can also be found in texts on heat flow (Ingersoll, Zobel, and Ingersoll, 1948, p. 90). When written using ground-water notation, and multiplying by 2 to account for the water contributed from both sides of the stream the equation has the form

$$Q_b = \frac{2s_0}{\sqrt{\pi t}} \sqrt{ST}. \quad (57)$$

Equations 56 and 57 now afford a means for evaluating the two unknowns  $T$  and  $S$ , inasmuch as the ratio  $S:T$  is determined from equation 56 and the product  $ST$  is obtained from equation 57.

Comparing equations 55 and 56 the use of the method of superposed graphs, described in previous sections, is again indicated as the most logical means of solution because  $\log s$  evidently varies with  $\log x^2/t$  in the same manner that  $\log D(u)_A$  varies with  $\log u^2$ . Thus the solution of equation 56 for the ratio  $S:T$  will evidently require matching a logarithmic data plot of values of  $s$  versus corresponding values of  $x^2/t$  (or simply  $1/t$  if only one observation well is available) to a logarithmic type curve prepared by plotting values of  $D(u)_A$  versus corresponding values of  $u^2$ . Such a type curve is shown in figure 31, prepared from the drain function values given in table 6.

If equations 56 and 57 are rewritten using the usual Survey units (except for  $Q_b$  which is the base flow in gallons per minute per foot of stream length), they become

$$u^2 = \frac{1.87x^2S}{Tt}, \quad (58)$$

and

$$Q_b = 2.15 \times 10^{-3} s_0 \sqrt{\frac{ST}{t}}. \quad (59)$$

TABLE 6.—Values of  $D(u)_A$ ,  $u$ , and  $u^2$  for channel method—constant head formula  
[Data for plotting type curve (fig. 31) for equation 56. Prepared by R. W. Stallman. Values of  $D(u)_A$  for selected values of  $u^2$  or  $u$ , were computed with the aid of U.S. Natl. Bureau of Standards tables (1954)].

$u$	$u^2$	$D(u)_A$	$u$	$u^2$	$D(u)_A$
0.03162	0.0010	0.9643	0.6325	0.40	0.3711
.04000	.0016	.9549	.7746	.60	.2733
.05000	.0025	.9436	.8944	.80	.2059
.06325	.0040	.9287	1.000	1.00	.1573
.07746	.0060	.9128	1.140	1.30	.1069
.08944	.0080	.8994	1.265	1.60	.0736
.1000	.010	.8875	1.378	1.90	.0513
.1266	.016	.8580	1.483	2.20	.0359
.1581	.025	.8231	1.581	2.50	.0254
.2000	.040	.7730	1.643	2.70	.0202
.2449	.060	.7291	1.732	3.00	.0143
.2828	.080	.6892	1.789	3.20	.0114
.3162	.10	.6548			
.4000	.16	.5716			
.6000	.25	.4795			

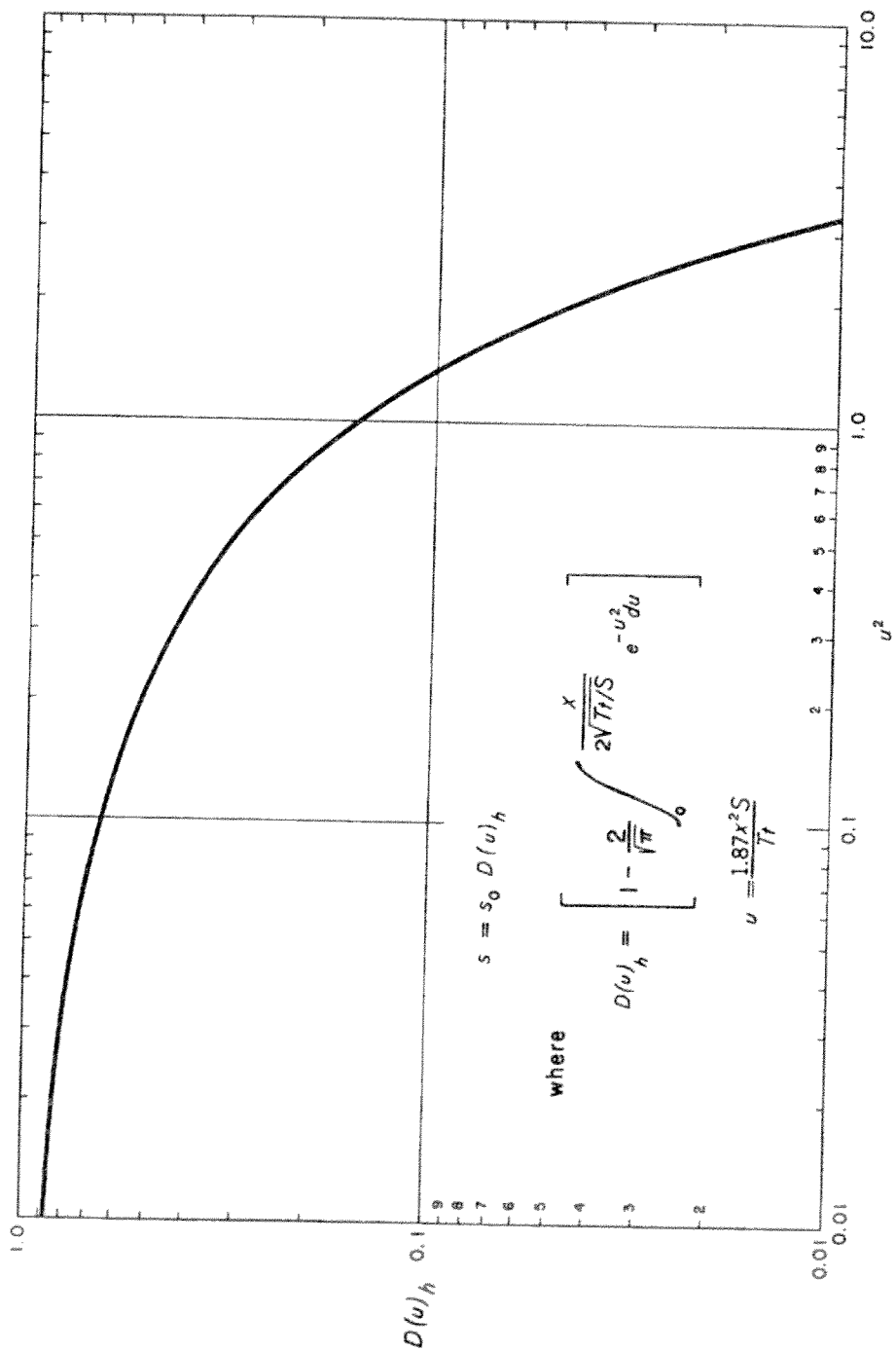

FIGURE 31.—Logarithmic graph of the drain function  $D(u)_h$  for channel method—constant head.



Equations 55 and 57 define the changes in head and flow which occur in the aquifer if the stream stage is abruptly changed. Therefore the stipulation of no recharge implies only that the rate of recharge must be constant for a sufficient interval of time, so that the regional water-level trends can be extrapolated with accuracy throughout the period in which the changes in the aquifer are being observed.

Water-level data from wells near the stream may, in some field situations, yield erratic results, depending on the flow pattern in the aquifer in the vicinity of the stream. For example, if the stream only partly penetrates the aquifer the flow lines in the aquifer will obviously bend upward as they approach the stream, thereby producing vertical components of flow. Thus the smaller the distance  $x$ , between observation well and stream, the greater the errors inherent in the observed water levels. This in turn means that as  $x$  decreases, the error in the computed value of  $S/T$  increases. It should also be realized that instantaneous or abrupt lowering of stream stage is seldom possible, which means that the determination of a reference or zero time is difficult. Thus observations made a short time after the stream stage is lowered may be somewhat unreliable. In general, therefore, it would seem prudent to favor the data collected at comparatively large values of  $x$  and large values of  $t$  to provide the most reliable basis for analysis.

Where it is known that the stream or drain penetrates only a part of the aquifer thickness, the following adjustment procedure, though not yet proven by field trial, may offer a means for determining more realistic values for  $T$  and  $S$ . It should be evident that in a field situation of this kind, the change in head in the stream channel is not as effective in producing head changes throughout the aquifer as when the stream is fully penetrating. Near the stream, groundwater levels adjust quickly to changes in stream stage, but part of the adjustment is caused by the bending of the flow lines. It can be assumed, however, that at some relatively short distance  $x_0$  away from the stream the bending of the flow lines in the aquifer will be small enough so that the effects on the head values may be neglected. Thus, for distances greater than  $x_0$  the flow lines may be considered parallel—that is, flow is essentially one-dimensional. The change in head in the aquifer, at the distance  $x_0$ , may therefore be considered as an effective value of  $s_0$  and it is related to the changes in head throughout the aquifer, for all distances greater than  $x_0$ , in the manner described by equations 55 and 56.

In effect this reasoning means that the real partly penetrating stream, in which the stage was abruptly changed an amount  $s_0$ , is being replaced (at the distance  $x_0$ ) by a theoretical fully penetrating stream in which the stage change may be regarded as essentially

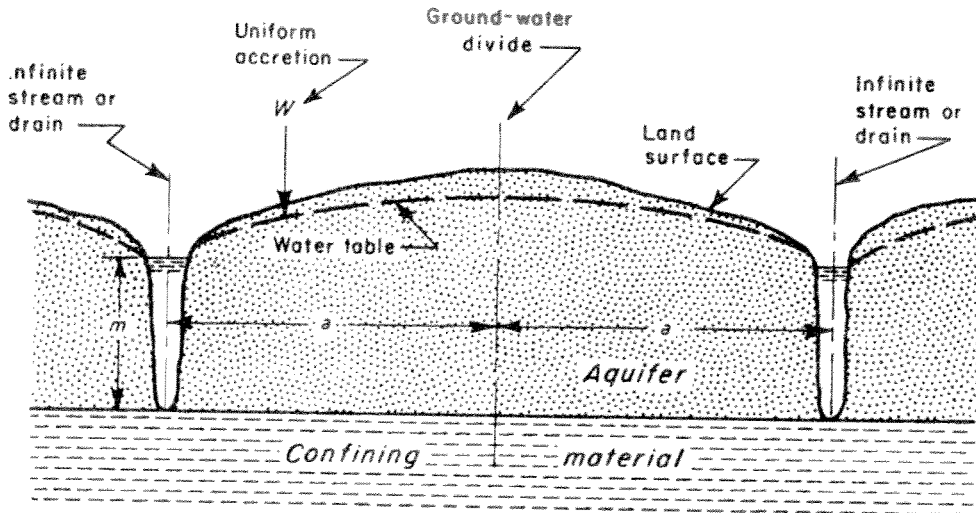

A. SECTION VIEW OF IDEAL AQUIFER SUBJECT TO UNIFORM ACCRETION, BOUNDED BY PARALLEL STREAMS

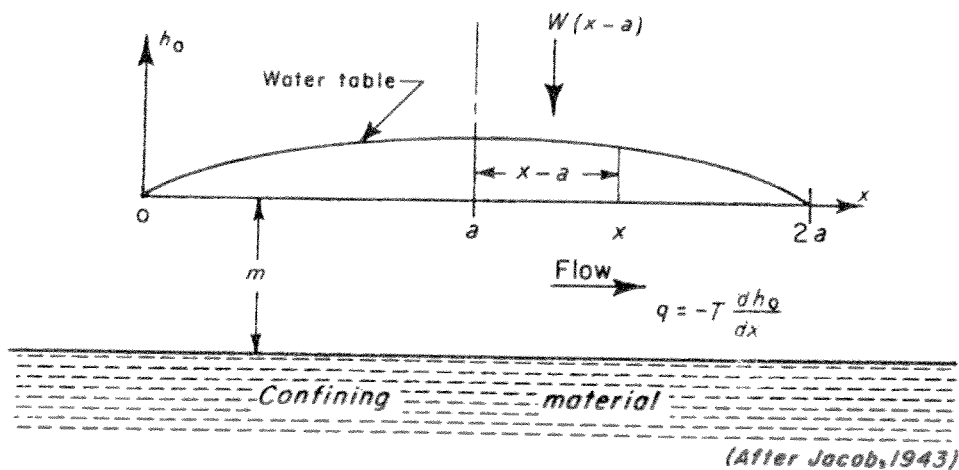

B. NOMENCLATURE FOR MATHEMATICAL ANALYSIS OF PROFILE SHOWN IN SKETCH

FIGURE 32.—Section views for analyzing steady-state flow in hypothetical aquifer of large thickness with uniform accretion from precipitation.

abrupt but of a lesser magnitude which shall be termed an effective value of  $s_0$ .

This so-called effective value of  $s_0$  can be computed from equation 55 after superposing the data and type curves in the manner already described. The critical distance  $x_0$  can also be computed, using the coordinates for a point common to the matched data and type curves, if more than one observation well is available. For each observation well the ratio  $S/T$  is computed, using the distance from the well to the real stream channel as a first estimate in equa-

tion 56. If the  $S/T$  values thus determined are not alike, the equation for  $u^2$  is adjusted to read as follows:

$$u^2 = \frac{1.87(x-x_0)^2 S}{Tt}$$

An estimate of  $x_0$  is then made, and  $S/T$  values for each observation well are recomputed using the effective distance to the stream ( $x=x_0$ ). If the data and field conditions are sufficiently ideal to permit an accurate analysis, several assumed values of  $x_0$  will indicate the one that will produce the closest agreement in the computed values of  $S/T$ .

It is pointed out that it is difficult to assess the true value of these adjustment procedures, inasmuch as the opportunity for applying them to a specific field problem has not yet been afforded.

#### STEADY STATE, UNIFORM RECHARGE

A problem of considerable practical interest is that of estimating the base flow of streams, or the effective average rate of ground-water recharge, from the shape of the water table. Consider the case of an aquifer bounded on two sides by fully penetrating parallel streams of infinite length as shown in figure 32A. It is assumed that the aquifer is homogeneous and isotropic, and that the aquifer is recharged at a rate of accretion,  $W$ , that is constant with respect to time and space. Flow is therefore one-dimensional and a ground-water divide is created at distance  $a$ , midway between the streams (see figure 32B). Jacob (1943, p. 566) has given the equation of steady-state profile as

$$h_0 = \left( \frac{a^2 W}{2T} \right) \left( \frac{2x}{a} - \frac{x^2}{a^2} \right),$$

or

$$\frac{T}{W} = \frac{ax}{h_0} - \frac{x^2}{2h_0}, \quad (60)$$

where

$W$  = constant rate of recharge to the water table;

$a$  = distance from the stream to the ground-water divide;

$x$  = distance from the stream to an observation well;

$h_0$  = elevation of the water table, at the observation well, with respect to the mean stream level.

It is frequently convenient to express the rate of recharge,  $W$ , in inches per year, while  $a$ ,  $x$ , and  $h_0$  are expressed in feet, and  $T$  is in the usual Survey units. Equation 60 is then rewritten in the form

$$T = 1.71(10^{-3}) W \left( \frac{ax}{h_0} - \frac{x^2}{2h_0} \right). \quad (61)$$

In the absence of artificial withdrawal of water from an aquifer, the net recharge must equal the natural discharge, provided changes in storage are insignificant. Although it is recognized that under natural conditions there are variations of  $W$  in time, it should be apparent that if average or mean ground-water levels are used in equation 61, a figure for  $W$  equivalent to an effective average accretion rate will result.

Equation 61 can be solved if the average (in time) contribution,  $Q_b$ , to the base flow of the stream, per unit length of channel can be determined from stream-flow measurements. If  $Q_b$  is expressed in gallons per minute per foot of stream channel, then

$$W = 8.44(10^6) \frac{Q_b}{2a},$$

or

$$W = 4.22(10^6) \frac{Q_b}{a}. \quad (62)$$

Equation 62 permits determination of  $W$  which can be used in equation 61 in computing the value of  $T$ .

In many field situations, of the type postulated here, general appraisal of the occurrence of ground water may indicate that the ground-water divide is parallel to the stream course, although the distance  $a$  will be unknown. If two observation wells are available, it is possible to compute a value for  $a$  and a value for the ratio  $586T/W$ . If a larger number of observation wells is available, a graphical solution may be used to solve for the values of  $a$  and  $586T/W$ . The procedure requires observation of the distances,  $x$ , from the stream to the individual observation wells and the corresponding values of  $h_0$ . Using the data from one observation well, and arbitrarily selecting several values of  $a$ , the corresponding values of  $586T/W$  are computed after appropriate substitution in equation 61. The computed values of  $586T/W$  are plotted against the corresponding assumed values of  $a$  and a smooth curve is drawn through the plotted points. In similar fashion a curve is drawn on the same graph for each observation well. The coordinates of the single point at which all the curves intersect give the particular values of  $a$  and of  $586T/W$  which will satisfy all the available data.

#### SINUSOIDAL HEAD FLUCTUATIONS

Werner and Noren (1951) and later Ferris (1951) independently analyzed the problem of fluctuations of water levels in wells in response to sinusoidal changes in stage of nearby surface-water bodies. The solution to this general type of problem has long been available in other fields of science and as Ferris indicates it may conveniently be

found in reference works on heat flow such as the text by Ingersoll, Zobel, and Ingersoll (1948, p. 46-47). Translated into ground-water terms, the solution requires an isotropic semi-infinite artesian aquifer of uniform thickness in full contact, along its one boundary, with a surface-water body that may be considered an infinite line source. Within the aquifer the change in water storage is assumed to occur instantaneously with, and at a rate proportional to, the change in pressure. Ferris (1951, p. 3) shows that the equation for the range of ground-water fluctuation in an observation well, a distance  $x$  from the aquifer contact with the surface-water body, whose stage is changing sinusoidally, has the nondimensional form

$$s_r = 2s_0 e^{-x\sqrt{\pi S/t_0 T}} \quad (63)$$

or, in the usual Survey units,

$$s_r = 2s_0 e^{-4.8x\sqrt{S/t_0 T}}, \quad (64)$$

where

$s_r$  = range of ground-water stage, in feet;

$s_0$  = amplitude or half range of the surface-water stage, in feet;

$x$  = distance from the observation well to the surface-water contact with the aquifer ("suboutcrop"), in feet;

$t_0$  = period of the stage fluctuation, in days;

$S$  = coefficient of storage; and

$T$  = coefficient of transmissibility, in gallons per day, per foot.

For convenience equation 64 can be written

$$2.1\sqrt{S/t_0 T} = \frac{-\log_{10}(s_r/2s_0)}{x} \quad (65)$$

The form of equation 65 suggests a semilogarithmic plot of the log of the range ratio,  $s_r/2s_0$ , for each observation well, versus the corresponding distance,  $x$ , as an expedient method of analyzing the observed data. The right-hand member of equation 65 represents the slope of the straight line that should be defined by the plotted data. If the change in the logarithm of the range ratio is selected over one log cycle of the plot, equation 65 becomes

$$2.1\sqrt{S/t_0 T} = \frac{1}{\Delta x},$$

or

$$T = \frac{4.4(\Delta x)^2 S}{t_0} \quad (66)$$

If the field conditions fulfill the assumptions made in deriving equation

66, the straight line drawn through the data on the semilogarithmic plot should pass through the origin of the coordinate axes—that is, should intercept a value of  $r/2s_0=1$  at a value of  $x=0$ . For the case of a stream of substantial width, partially penetrating the artesian aquifer, this intercept will usually be found at negative values of  $x$ , indicating an “effective” distance offshore to the suboutcrop. This effective distance may or may not have physical significance depending on the nature of the flow field in the vicinity of the stream. For example, if the stream does not cut through the upper confining bed, stage changes in the surface-water body may still provide, through the changes in loading that are involved, a source of sinusoidal head fluctuation in the artesian aquifer along the stream location. Unless the loading changes are completely effective (100 percent tidal efficiency) in producing a stage range of  $2s_0$  at  $x=0$  in the aquifer, the straight-line intercept with the  $x$  axis will again be at some negative value of  $x$ , and will in part be an indication of the efficiency with which the aquifer skeleton accepts the changes in loading. However, it should be observed that regardless of the exact value of  $s_0$  in the aquifer, at  $x=0$ , the slope of the data plot described is unaffected. Therefore the  $T$  value computed by means of equation 66 will be correct regardless of the actual value in the aquifer of  $s_0$ .

It is seen from equation 66 that it is necessary to know  $S$  in order to solve for  $T$ . Frequently, when the coefficient of storage is not known, it is possible to make a reasonable estimate of its value by studying the well logs and water-level records.

The lag in time of occurrence of a given maximum or minimum ground-water stage, following the occurrence of a similar surface-water stage, is given by Ferris (1951) as

$$t_1 = \frac{x}{2} \sqrt{\frac{t_0 S}{\pi T}} \quad (67)$$

where  $t_1$  is the lag in time. Solving this equation for the coefficient of transmissibility, and rewriting in terms of the usual Survey units, there follows

$$T = 0.60 t_0 S \left( \frac{x}{t_1} \right)^2 \quad (68)$$

The only variables in equation 68 are evidently  $x$  and  $t_1$ . Thus an arithmetic plot is suggested with the value of the distance,  $x$ , for each observation well, plotted against the corresponding value of the time lag,  $t$ . The slope of the straight line that should be defined by these plotted points will then give the value of  $x/t_1$ , which appears to the second power in equation 68. If the straight line that is drawn



through the plotted points should intersect the zero-timelag axis at a negative value of  $x$  it may be an indication of the effective distance offshore to the suboutcrop.

In those situations where the aquifer is not fully penetrated or where it is under water-table (unconfined) conditions, the methods of analysis described in this section will be satisfactory if (a) the observation wells are far enough from the suboutcrop so that they are unaffected by vertical components of flow and (b) the range in fluctuations is only a small fraction of the saturated thickness of the formation.

#### AREAL METHODS

##### NUMERICAL ANALYSIS

By R. W. STALLMAN

The equations presented in the preceding sections of this paper were derived by means of the calculus. Darcy's law combined with the equation of continuity (Rouse, 1950, p. 326) yielded the basic differential equations that described states of flow. In turn, solutions to these differential equations were found that satisfy the boundary conditions of a particular problem. Certain generalizations were made in regard to the boundary conditions so as to provide rather specific equations, which can be used with convenience to obtain a solution to the field problem. Among these generalizations are the assumptions of a constant head or discharge at some point or line, homogeneity of the aquifer, simple geometric form or shape of the aquifer, and complete penetration of the well or stream. Certainly for many field problems these conditions are fulfilled to a sufficient degree that the available formulas can be used to obtain reliable approximations of the values of  $T$ ,  $S$ , or  $W$ . However, the ground-water hydrologist frequently encounters problems for which the complicated boundary conditions cannot be expressed by simple mathematical relations. Furthermore, the complicated boundary conditions related to a given field problem seldom recur in nature in the same combination. Thus it could be poor economy to spend a large amount of time and energy deriving complicated analytical equations whose application might be limited to one problem. Under such circumstances it may be found more expedient to use numerical methods of analysis for the quantitative investigation. Numerical methods have been used in other sciences for some time for the same purpose. Basic formulas and procedures have been described by Southwell (1946, 1940) and many of his colleagues (Shaw, 1953). Scarborough (1950) and Milne (1953) have written extensively on the same subject and an application of numerical methods to ground-water investigations has been described by Stallman (1956).

The formal derivation of analytical equations for describing ground-

water movement involves application of the rules of calculus for integrating, or summing, an infinite set of infinitesimal changes in head between two or more points in the flow region under study. In lieu of application of the rules of calculus to perform this addition conveniently, it would be possible to accomplish the same thing simply by addition of the infinite set of infinitesimals. The latter method is, of course, impractical unless approximations are introduced. Thus an area may be calculated by considering that it is composed of small but finite parts, each having an area  $(\Delta x)(\Delta y)$ . By means of this more coarse subdivision of the area, the problem is reduced to the addition of a sensibly small and finite set of component parts instead of the infinite set of infinitesimal areas  $(dx)(dy)$  postulated by the orthodox calculus. In brief this constitutes the basis of numerical analysis as applied in finding solutions to differential equations: the substitution of finite entities for the differential forms that appear in the fundamental differential equations.

Consider, for example, the differential equation describing two-dimensional unsteady flow in a homogeneous and isotropic aquifer, subject to recharge at a steady rate of accretion  $W$ . It can be shown that this equation has the form

$$\frac{\partial^2 h}{\partial x^2} + \frac{\partial^2 h}{\partial y^2} = \left(\frac{S}{T}\right) \frac{\partial h}{\partial t} - \frac{W}{T}, \quad (69)$$

where  $h$  is the head at any point whose coordinates are  $x, y$ . Let the differential lengths  $dx$  and  $dy$  be expanded so that each can be considered equivalent to a finite length  $w$ , and similarly let  $dt$  be considered equivalent to  $\Delta t$ . A plan representation of the region of flow to be studied may then be subdivided by two systems of equally spaced parallel lines at right angles to each other. One system is oriented in the  $x$  direction and the other in the  $y$  direction and the spacing of the lines equals the distance  $w$  (see fig. 33). A set of 5 gridline intersections or nodes, selected in the manner shown on figure 33, is called an array. According to Southwell (1946, p. 19) the first two differentials in equation 69 can be expressed, in terms of the head values at the nodes in the array, in the following fashion:

$$\frac{\partial^2 h}{\partial x^2} \approx \frac{h_1 + h_3 - 2h_0}{w^2}$$

and

$$\frac{\partial^2 h}{\partial y^2} \approx \frac{h_2 + h_4 - 2h_0}{w^2},$$

where the subscripts of  $h$  refer to the numbered nodes of figure 33. Substituting these equivalent expressions for the first two differentials



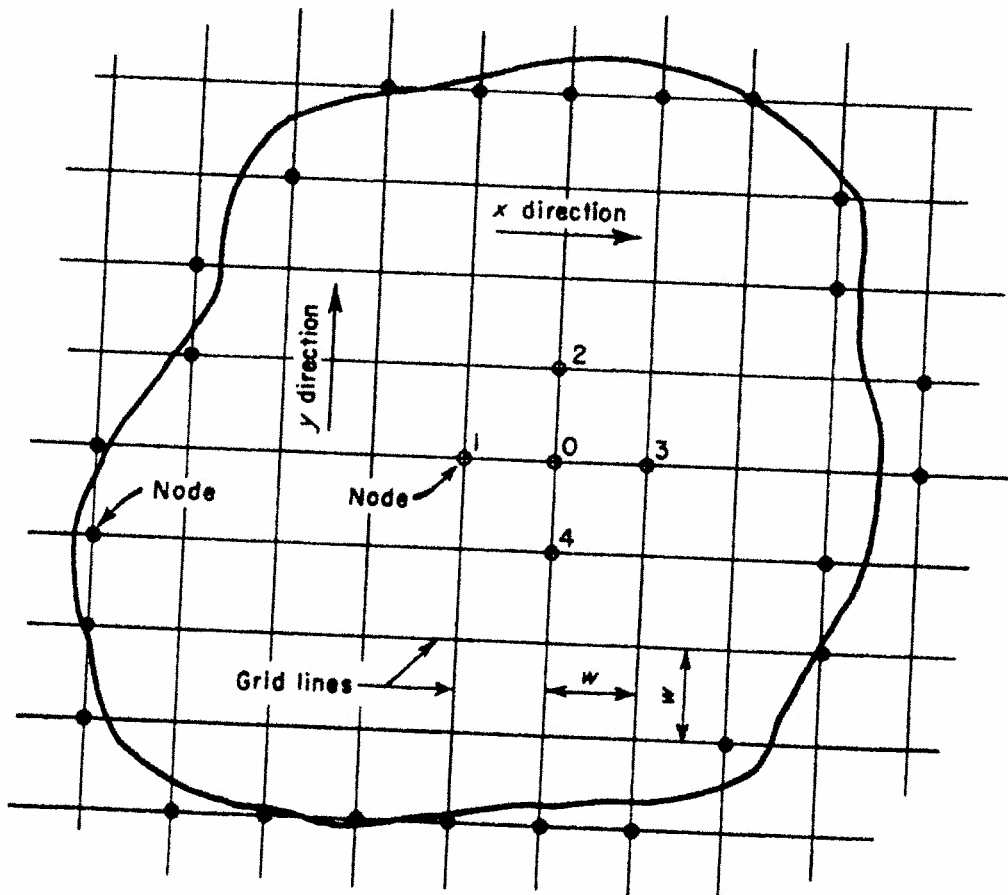

## NOTES:

Filled circles indicate boundary nodes selected to approximate irregular boundary of the area

The grid spacing  $w$  is an approximation of the differential distances  $dx$  and  $dy$

The five numbered nodes constitute an array

FIGURE 23.—Finite grid and nomenclature used in numerical analysis.

in equation 69, and letting  $\partial h/\partial t$  be considered equivalent to  $\Delta h_{0i}/\Delta t$ , there follows

$$h_1 + h_2 + h_3 + h_4 - 4h_0 = \left[ \frac{S}{T} \left( \frac{\Delta h_{0i}}{\Delta t} \right) - \frac{W}{T} \right] w^2, \quad (70)$$

where  $\Delta h_{0i}$  is the change in head which occurs at node 0 through the time interval  $\Delta t$ . Depending on the type of data available, equation 70 can be used to compute the ratios  $S/T$  and  $W/T$ , or the head distribution in time and space, in an aquifer of given size and shape.

Furthermore, the calculations involve only the use of simple arithmetic.

In working out a solution where a finite difference equation such as equation 70 is being applied to a problem in which the head distribution is required, the primary aim of the computing methods is to find the particular head values at all the nodal points (like points 0-4 of figure 33) such that the finite difference equation is satisfied at all nodes simultaneously. This head distribution can be found either by "relaxation" or "iteration" methods of numerical analysis. The computations are begun by assuming head values for all the nodes in the flow system. These initial estimates will not ordinarily satisfy the finite difference equation and will require revision so that the equation will be satisfied at all points in the grid. Refinement of the head values is continued until accuracy is considered to be sufficient for the needs of the problem.

If the refinement is made using a routine adjustment procedure, it is termed an iteration method; if it is made by approximation, it is termed a relaxation method. Consider the steady-state form of equation 70, which is

$$h_1 + h_2 + h_3 + h_4 - 4h_0 + \left(\frac{W}{T}\right)w^2 = 0. \quad (71)$$

Assume that it is desired to find the head distribution in an aquifer of known size and shape, the flow conditions (and/or head values) being known along its perimeter, and the values of  $W$  and  $T$ , or their ratio, being known. Substituting in equation 71 the initial set of assumed head values for nodes 0-4, and the known value of  $(W/T)w^2$  there follows

$$h_{1i} + h_{2i} + h_{3i} + h_{4i} - 4h_{0i} + \left(\frac{W}{T}\right)w^2 = R_0, \quad (72)$$

where the subscript  $i$  is used to set apart or distinguish the head values that are initially assumed. The term  $R_0$  is the residual at node zero; in other words, it is the remainder resulting from summation of the assumed and known values on the left side of the equation. Inasmuch as it is virtually impossible to assume an initial set of head values such that the summation indicated in equation 71 is zero, there will almost inevitably be a remainder or residual as shown in equation 72. This residual,  $R_0$ , may be thought of as an indication of the amount and direction of excess curvature on the piezometric surface defined by the assumed heads. The value of  $R_0$  is also an indication of the amount by which  $h_{0i}$  must be changed so that in the next trial summation of head values the result will more closely approach the zero value required for complete satisfaction of equation 71.

It can easily be shown that if the head at the zero node is changed by an amount  $\Delta h_0 = -R_0/4$ , the residual at that node will be reduced to zero. However, it should be kept in mind that equation 71 is to be tried on each array in the grid net and that residuals will appear at many if not all of the other nodes. Thus a head adjustment at one node will affect residuals at other nodes, and conversely subsequent head adjustments at adjacent nodes will affect the residual at the first zero node. Accordingly, several circuits must be made through the net before the residual values are reduced to zero or nearly zero. Successive circuits of nodal head adjustments amounting to  $-R_0/4$ , applied regularly over the net, constitute an iterative process. With practice the computer will recognize that the distribution of residuals can be improved more efficiently by either a larger or smaller head adjustment than indicated by  $-R_0/4$ . Applying such improvement tempered by judgment gained from experience is a relaxation method.

#### FLOW-NET ANALYSIS

By R. R. BENNETT

In analyzing problems of ground-water flow, a graphical representation of the flow pattern is of considerable assistance and often provides the only means of solving those problems for which a mathematical solution is not practicable. The first significant development in graphical analysis of flow patterns was made by Forchheimer (1930).

A "flow net," which is a graphical solution of a flow pattern, is composed of two families of lines or curves. One family of curves represents the streamlines or flow lines, where each curve indicates the path followed by a particle of water as it moves through the aquifer in the direction of decreasing head. Intersecting the streamlines at right angles is a family of curves termed equipotential lines, which represent contours of equal head in the aquifer.

Although the real flow pattern contains an infinite number of flow lines and equipotential lines, it may be conveniently represented by constructing a net that uses only a few of those lines. The flow lines are selected so that the total quantity of flow is divided equally between adjacent pairs of flow lines; similarly the equipotential lines are selected so that the total drop in head across the system is evenly divided between adjacent pairs of potential lines.

The change in potential, or drop in head between two equipotential lines in an aquifer, divided by the distance traversed by a particle of water moving from the higher to the lower potential determines the hydraulic gradient. Recognizing that this movement of a water particle is governed in part by the proposition that the flow path adopted will be the one involving the least work—that is, the shortest possible path between the two equipotential lines in question—it follows that

the direction of water movement is everywhere synonymous with paths that are normal to the equipotential lines. Hence the system of flow lines must be drawn orthogonal to the system of equipotential lines.

A flow net constructed with the foregoing principles in mind is a pattern of "rectangles" in which the ratio of the mean dimensions of each "rectangle" is constant. If the net is constructed so that the sides of each rectangle are equal, then the net is a system of "squares." It should be recognized, however, that in flow fields involving curved paths of flow, the elemental geometric forms in the net are curvilinear and thus are not true squares; however, the corners of each "square" are right angles and the mean distances between the two pairs of opposite sides are equal. If any one of these elemental curvilinear "squares" is repeatedly subdivided into four equal parts the subdivisions will progressively approach the shape of true squares.

The proper sketching of a flow net by the graphical method is something of an art that is learned by experience; however, the following points summarized from a paper by Casagrande (1937, p. 136-137) may be helpful to the beginner:

1. Study the appearance of well-constructed flow nets and try to duplicate them by independently reanalyzing the problems they represent.
2. In the first attempts at sketching use only four or five flow channels.
3. Observe the appearance of the entire flow net; do not try to adjust details until the entire net is approximately correct.
4. Frequently parts of a flow net consist of straight and parallel lines, which result in uniformly sized true squares. By starting the sketching in such areas, the solution can be obtained more readily.
5. In flow systems having symmetry (for example, nets depicting radial flow into a well) only a section of the net need be constructed, as the other part or parts are images of that section.
6. During the sketching of the net, keep in mind that the size of the square changes gradually; all transitions are smooth and, where the paths are curved, are of elliptical or parabolic shape.

Taylor (1948) recommends a somewhat different procedure for sketching flow nets. This procedure, called the procedure of explicit trials, has been found to have value in developing intuition for flow-net characteristics. In this method a trial equipotential or flow line is established and the entire net completed as if that trial line were correct. If the completed net is not correct, the initial trial line is resketched and a new net is constructed. The adjustment of the trial line is judged from the appearance of the entire net and how well it conforms to the boundary conditions of the system.

For steady flow, with a particular set of boundary conditions, only one flow net exists. If at some subsequent time the boundary conditions are altered, then after sufficient time has elapsed to reestablish the steady state, a different flow pattern would be developed and again there would be only one possible solution for the new set of boundary conditions. Thus before attempting to construct a flow net, it is important that the boundary conditions be established and carefully described. For example, consider the aquifer shown in figure 34, bounded by an impermeable barrier paralleling a perennial stream. Line AB, designating the stream, is obviously an equipotential line along which the head is equal; line CD marking the impermeable barrier, is evidently coincident with the limiting or boundary flow line. Accordingly, the equipotential lines will adjoin the barrier at right angles. The discharge through any channel or path of the flow net may be obtained with the aid of Darcy's law, one variation of which, as has been previously shown, may be written in the form

$$Q=PIA.$$

For convenience in applying this variation of Darcy's law, consider a unit width or thickness of the aquifer, measured normal to the direction of flow indicated by  $L$  in figure 34—that is, normal to the plane of the diagram. The preceding equation may then be rewritten for this unit thickness (in this example) of aquifer, and for one flow channel through the net as

$$\Delta q=PIb, \quad (73)$$

where  $\Delta q$  represents the flow occurring between a pair of adjacent flow lines (one flow channel) and  $b$  is the spacing of the flow lines. If  $L$  represents the spacing, and  $\Delta h$  the drop in head, between the equipotential lines, equation 73 becomes

$$\Delta q=P\Delta h \left( \frac{b}{L} \right). \quad (74)$$

Inasmuch as the flow net (figure 34) was constructed to comprise a system of "squares" the ratio  $b/L$  is equal to unity and the same potential drop occurs across each "square". It follows then from equation 74 that the same incremental flow,  $\Delta q$ , occurs between each pair of adjacent flow lines. If there are  $n_r$  flow channels, the total flow,  $q$ , through a unit thickness of the aquifer, is given by

$$q=n_r\Delta q. \quad (75)$$

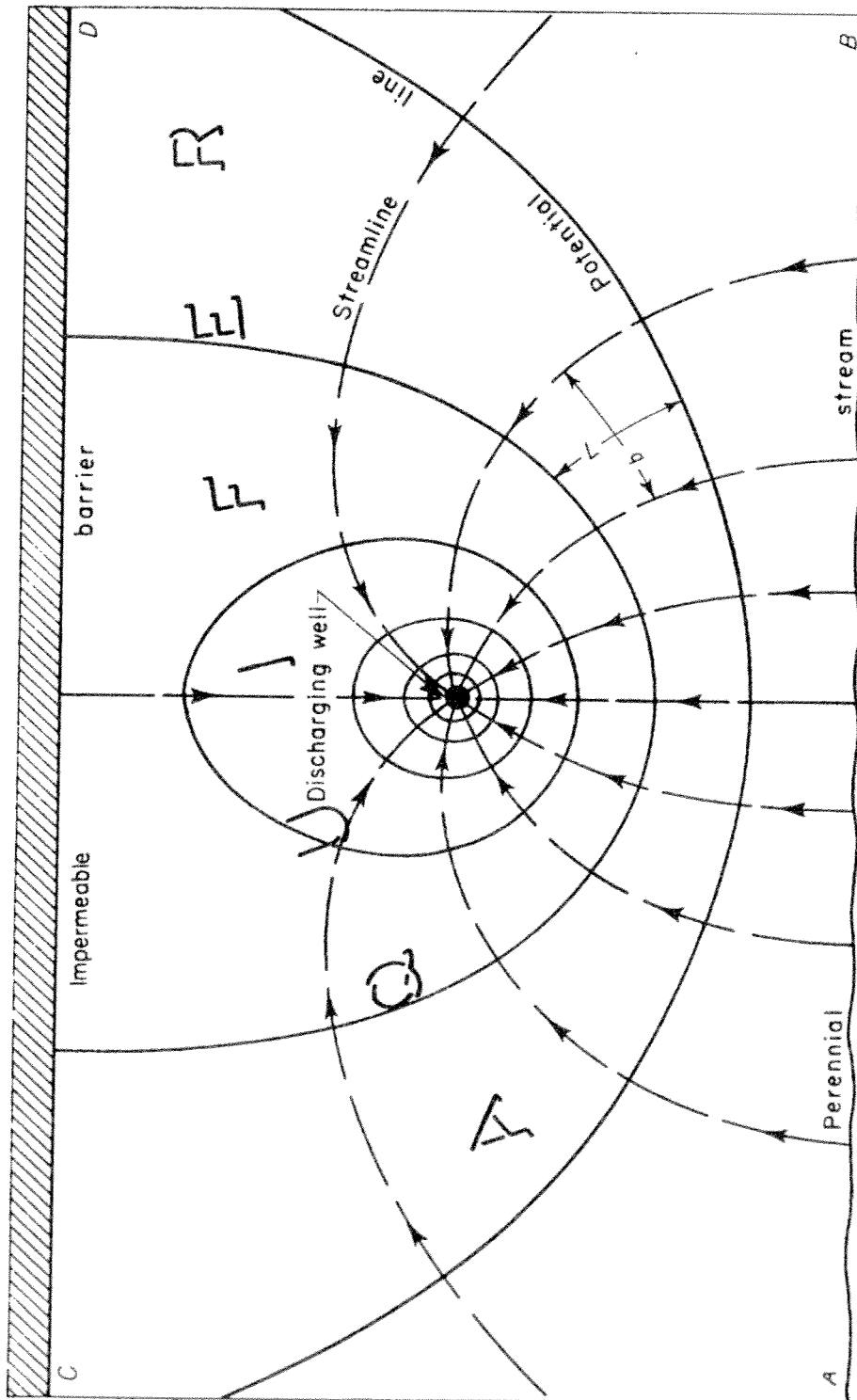

FIGURE 34.—Flow net for a discharging well in an aquifer bounded by a perennial stream parallel to an impermeable barrier.

If there are  $n_d$  potential drops, the total drop in head,  $h$ , is given by

$$h = n_d \Delta h. \quad (76)$$

Substituting in equation 75 the values of  $\Delta q$  and  $\Delta h$  given by equations 74 and 76 respectively, there follows

$$q = \frac{n_f}{n_d} P h. \quad (77)$$

Noting that  $q$  represents the total flow through a unit thickness of the aquifer, the equation for total flow through the full thickness of the aquifer becomes

$$Q = \frac{n_f}{n_d} P h m, \quad (78)$$

where  $Q$  = flow through full thickness of the aquifer in gallons per day;

$n_f$  = number of flow channels;

$n_d$  = number of potential drops;

$P$  = coefficient of permeability of the aquifer material, in gallons per day per square foot;

$m$  = saturated thickness of aquifer, in feet;

$h$  = total potential drop, in feet; and

$Pm$  = transmissibility of the aquifer, in gallons per day per foot.

The preceding discussion of the graphical construction of flow nets concerns two-dimensional flow fields in homogeneous and isotropic media. The graphical construction of flow nets for three-dimensional problems generally is impracticable; however, many ground-water problems of a three-dimensional nature can be reduced to two dimensions without introducing serious errors.

For two-dimensional problems involving simple anisotropy, such as a constant difference between the vertical and horizontal permeability, or a directional areal transmissibility, the flow net can be constructed by the conventional graphical procedure (system of squares) provided the flow field is first transformed to account for the anisotropy. If the values of maximum or minimum permeability (or transmissibility) are designated  $P_{\max}$ , and  $P_{\min}$ , all the dimensions in the direction of  $P_{\max}$  must be reduced by the factor  $\sqrt{P_{\min}/P_{\max}}$ ; or, all dimensions in the direction of  $P_{\min}$  must be increased by the factor  $\sqrt{P_{\max}/P_{\min}}$ . After the flow field is transformed, the net is constructed by graphical methods. Then the net is projected back to the original dimensions of the field. It will be found that the



projected net generally will no longer be a system of squares, and the equipotential and stream lines will not intersect at right angles.

For areally nonhomogeneous aquifers—that is, those comprising subareas of homogeneous and isotropic media but of different transmissibility—the flow pattern cannot, according to theory, be represented by a single system of squares. If the flow net were constructed so that each flow path conducted the same quantity of water, one subarea could be represented by a system of squares, but the nets in the other subareas would consist of rectangles in which the ratio of the lengths of the sides would be proportional to the differences in transmissibility. If the flow lines from one subarea enter another subarea at an angle, the flow lines (and equipotential lines) would be refracted according to the tangent law. The graphical construction of a flow net under such conditions is extremely difficult and, with the data that are available for most ground-water problems, is generally impossible. However, Bennett and Meyer (1952, p. 54–58) have shown that by generalizing the flow net for such an area into a system of squares and determining the quantity of flow by making an inventory of pumpage in each of the subareas, the approximate transmissibility of the subareas may be determined. Although such an application of the method departs somewhat from theory, it is likely that for many areas it provides more realistic areal transmissibilities than could be obtained by use of pumping-test methods alone. Whereas pumping tests may provide accurate values of transmissibilities they generally represent only a small “sample” of the aquifer. Flow-net analysis on the other hand may include large parts of the aquifer, and hence provide an integrated and more realistic value of the areal transmissibility. Moreover, by including comparatively large parts of the aquifer, the local irregularities that may appreciably affect some pumping-test analyses generally have an insignificant effect on the overall flow patterns.

The application of flow-net analysis to ground-water problems has not received the attention it deserves; however as the versatility of flow-net analysis becomes more widely known, its use will become more common. Such a method of analysis greatly strengthens the hydrologist's insight into ground-water flow systems; it provides quantitative procedures for analyzing and interpreting contour maps of the water-table and piezometric surfaces.

For other illustrations of flow-net construction, see figures 36 and 38.

#### **THEORY OF IMAGES AND HYDROLOGIC BOUNDARY ANALYSIS**

The development of the equilibrium and nonequilibrium formulas discussed in the preceding sections was predicated in part on the as-



sumption of infinite areal extent of the aquifer, although it is recognized that few if any aquifers completely satisfy this assumption. In many instances the existence of boundaries serves to limit the continuity of the aquifer, in one or more directions, to distances ranging from a few hundred feet to as much as tens of miles. Thus when an aquifer is recognized as having finite dimensions, direct analysis of the test data by the equations previously given is often precluded. It is often possible, however, to circumvent the analytical difficulties posed by the aquifer boundary. The method of images, widely used in the theory of heat conduction in solids, provides a convenient tool for the solution of boundary problems in ground-water flow. Imaginary wells or streams, usually referred to as images, can sometimes be used at strategic locations to duplicate hydraulically the effects on the flow regime caused by the known physical boundary. Use of the image thus is equivalent to removing a physical entity and substituting a hydraulic entity. The finite flow system is thereby transformed by substitution into one involving an aquifer of infinite areal extent, in which several real and imaginary wells or streams can be studied by means of the formulas already given. Such substitution often results in simplifying the problem of analysis to one of adding effects of imaginary and real hydraulic systems in an infinite aquifer.

An aquifer boundary formed by an impermeable barrier, such as a tight fault or the impermeable wall of a buried stream valley that cuts off or prevents ground-water flow, is sometimes termed a "negative boundary." Use of this term is discouraged, however, in favor of the more meaningful and descriptive term "impermeable barrier." A line at or along which the water levels in the aquifer are controlled by a surface body of water such as a stream, or by an adjacent segment of aquifer having a comparatively large transmissibility or water-storage capacity, is sometimes termed a "positive boundary." Again, however, use of the term is discouraged in favor of the more precise terms line source or line sink, as may be appropriate.

Although most geologic boundaries do not occur as abrupt discontinuities, it is often possible to treat them as such. When conditions permit this practical idealization, it is convenient for the purpose of analysis to substitute a hypothetical image system for the boundary conditions of the real system.

In this section, where the analysis of pumping-test data is considered, several examples are given of image systems required to duplicate, hydraulically, the boundaries of certain types of areally restricted aquifers. It should be apparent that similar methods can be used to analyze flow to streams or drains through areally limited aquifers.

## PERENNIAL STREAM—LINE SOURCE AT CONSTANT HEAD

An idealized section through a discharging well in an aquifer hydraulically controlled by a perennial stream is shown in figure 35A. For thin aquifers the effects of vertical-flow components are small at relatively short distances from the stream, and if the stream stage is not lowered by the flow to the real well there is established the boundary condition that there shall be no drawdown along the stream position. Therefore, for most field situations it can be assumed for practical purposes that the stream is fully penetrating and equivalent

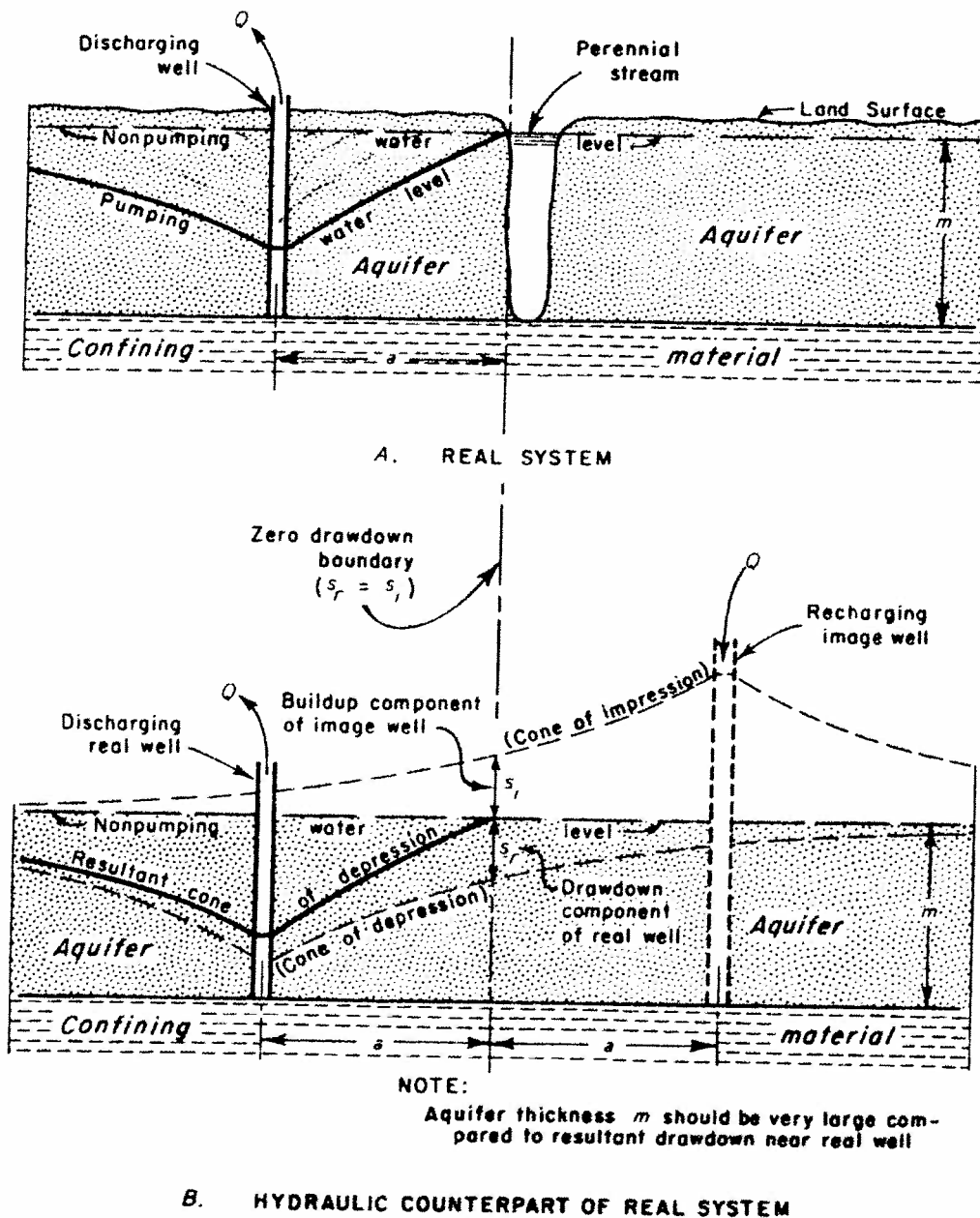

FIGURE 35.—Idealized section views of a discharging well in a semi-infinite aquifer bounded by a perennial stream, and of the equivalent hydraulic system in an infinite aquifer.

to a line source at constant head. An image system that satisfies the foregoing boundary condition, as shown in figure 35*B*, allows a solution of the real problem through use, in this example, of the Theis non-equilibrium formula. Note in figure 35*B* that an imaginary recharging well has been placed at the same distance as the real well from the line source but on the opposite side. Both wells are situated on a common line perpendicular to the line source. The imaginary recharge well operates simultaneously with the real well and returns water to the aquifer at the same rate that it is withdrawn by the real well. It can be seen that this image well produces a buildup of head everywhere along the position of the line source that is equal to and cancels the drawdown caused by the real well which satisfies the boundary condition of the problem. The resultant drawdown at any point on the cone of depression in the real region is the algebraic sum of the drawdown caused by the real well and the buildup produced by its image. The resultant profile of the cone of depression, shown in figure 19*B*, is flatter on the landward side of the well and steeper on the riverward side, as compared with the shape it would have if no boundary were present. Figure 36 is a generalized plan view of a flow net for the situation given in figure 35*A*. The distribution of stream lines and potential lines about the real discharging well and its recharging image, in an infinite aquifer, is shown. If the image region is omitted, the figure represents the stream lines and potential lines as they might be observed in the vicinity of a discharging well obtaining water from a river by induced infiltration.

#### IMPERMEABLE BARRIER

An idealized section through a discharging well in an aquifer bounded on one side by an impermeable barrier is shown in figure 37*A*. It is assumed that the irregularly sloping boundary can, for practical purposes, be replaced by a vertical boundary, occupying the position shown by the vertical dashed line, without sensibly changing the nature of the problem. The hydraulic condition imposed by the vertical boundary is that there can be no ground-water flow across it, for the impermeable material cannot contribute water to the pumped well. The image system that satisfies this condition and permits a solution of the real problem by the Theis equation is shown in figure 37*B*. An imaginary discharging well has been placed at the same distance as the real well from the boundary but on the opposite side, and both wells are on a common line perpendicular to the boundary. At the boundary the drawdown produced by the image well is equal to the drawdown caused by the real well. Evidently, therefore, the drawdown cones for the real and the image wells will be symmetrical and will produce a ground-water divide at every point along the boundary line. Because there can be no flow

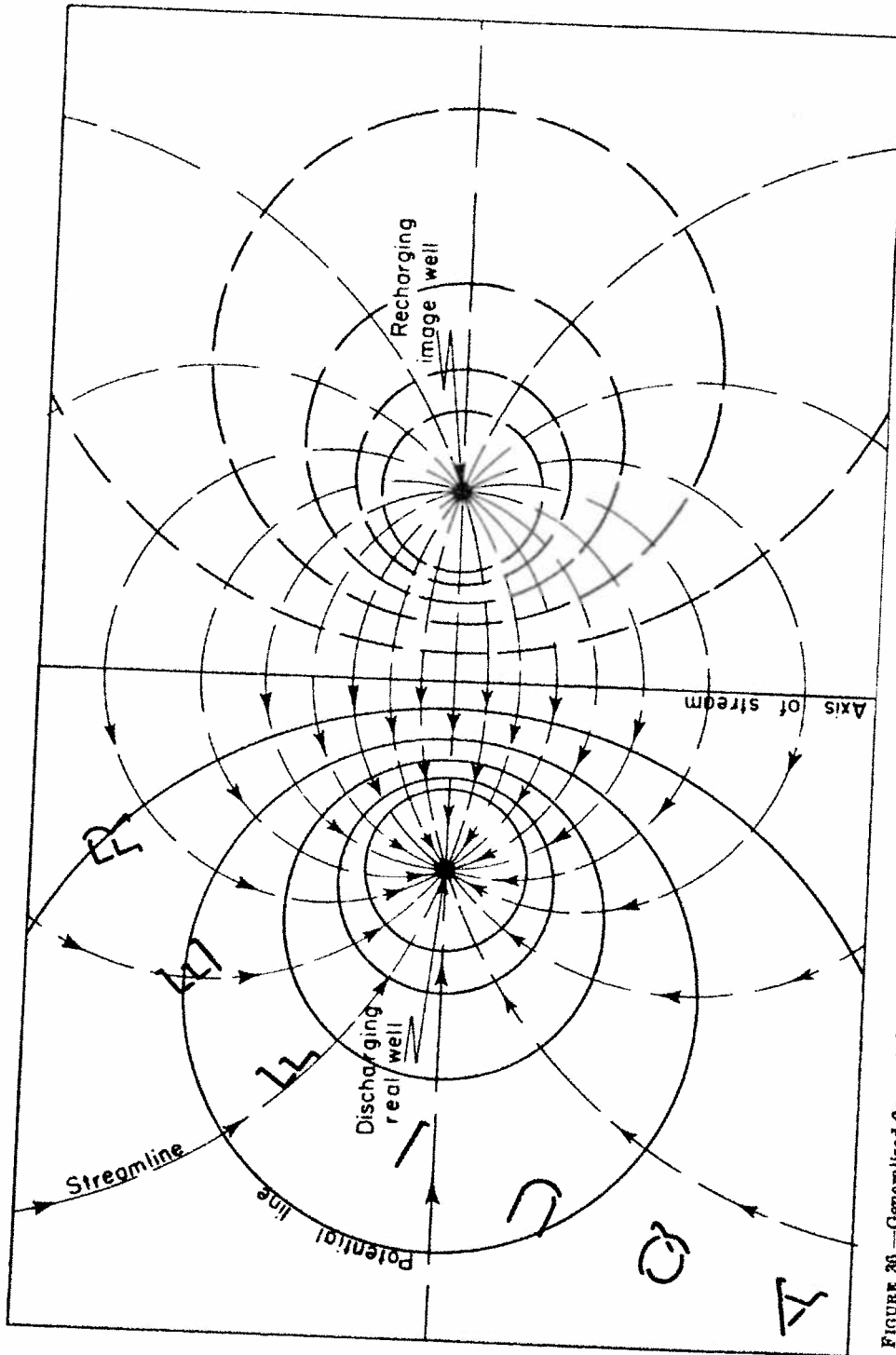
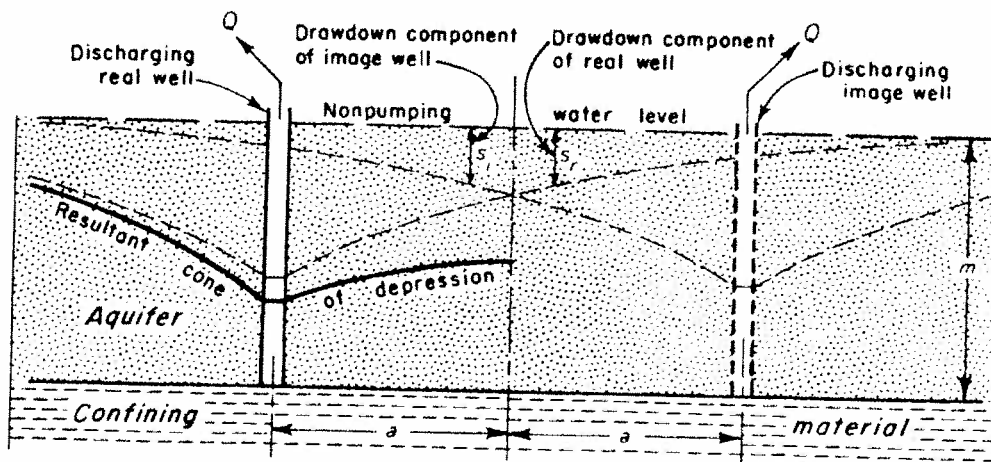
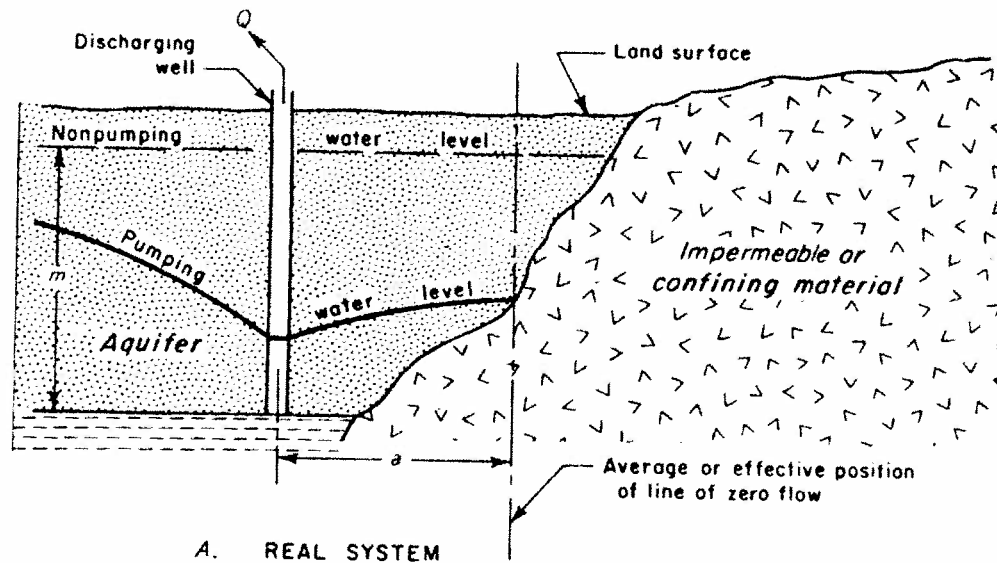

FIGURE 30.—Generalized flow net showing stream lines and potential lines in the vicinity of a discharging well dependent upon induced infiltration from a nearby stream.



NOTE:

Aquifer thickness  $m$  should be very large compared to resultant drawdown near real well

FIGURE 37.—Idealized section views of a discharging well in a semi-infinite aquifer bounded by an impermeable formation, and of the equivalent hydraulic system in an infinite aquifer.

across a divide, the image system satisfies the boundary condition of the real problem and analysis is simplified to consideration of two discharging wells in an infinite aquifer. The resultant drawdown at any point on the cone of depression in the real region is the algebraic sum of the drawdowns produced at that point by the real well and its image. The resultant profile of the cone of depression, shown in figure 37B, is flatter on the side of the well toward the boundary and steeper on the opposite side away from the boundary than it would be if no boundary were present. Figure 38 is a general-

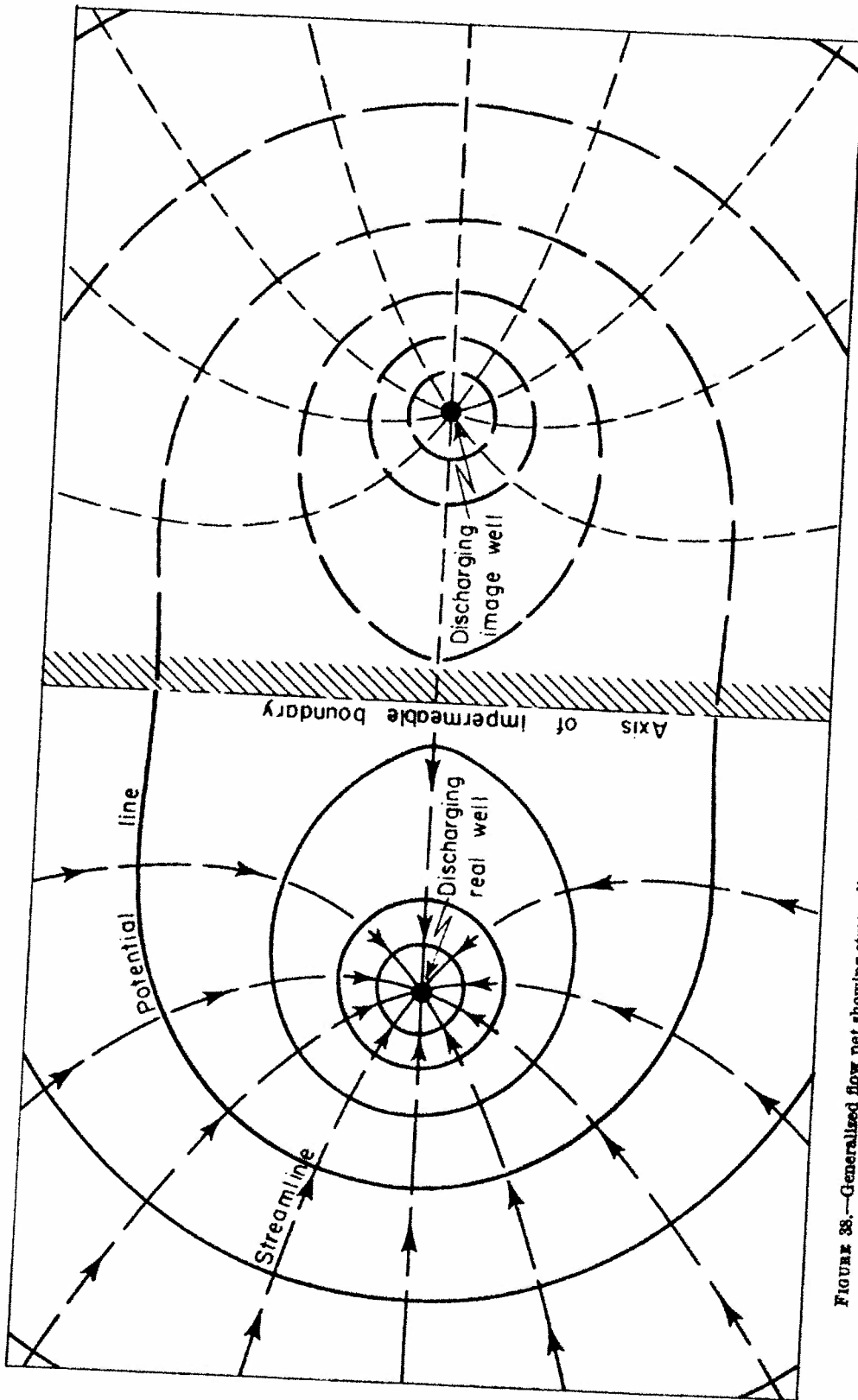
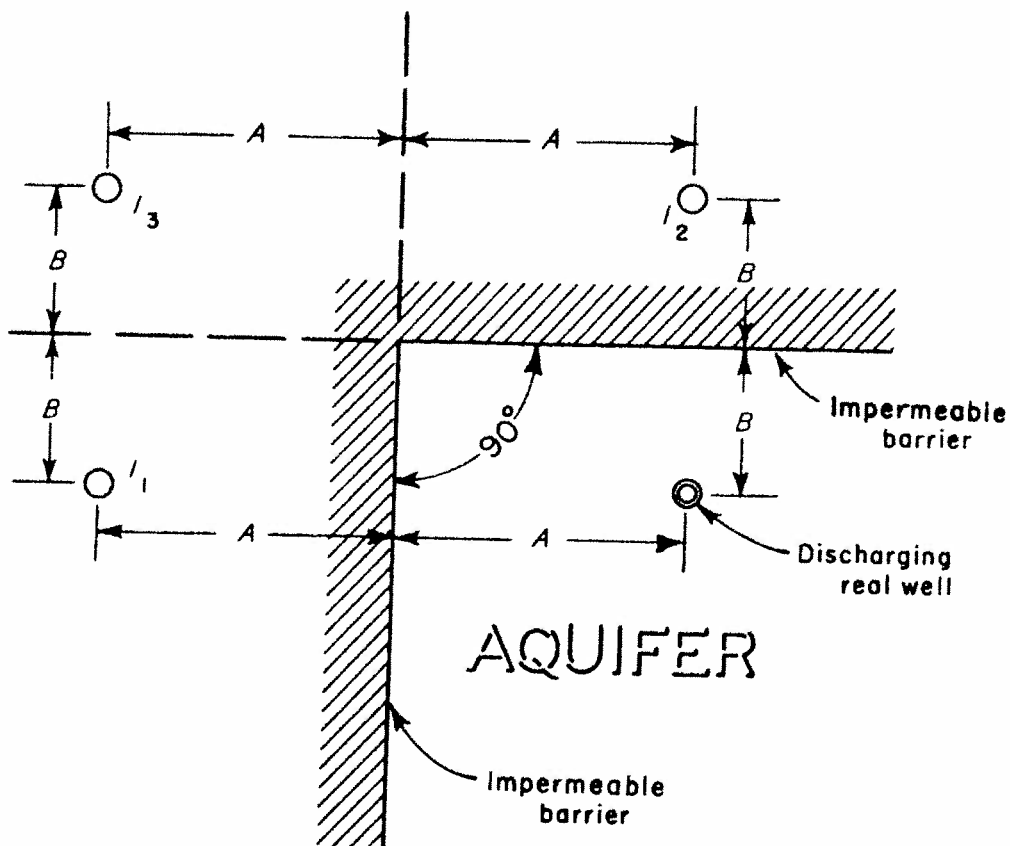

FIGURE 38.—Generalised flow net showing stream lines and potential lines in the vicinity of a discharging well near an impermeable boundary.

ized plan view of a flow net for the situation given in figure 37A. The distribution of stream lines and potential lines about the real discharging well and its discharging image, in an infinite aquifer, is shown. If the image region is omitted, the diagram represents the flow net as it might be observed in the vicinity of a discharging well located near an impermeable boundary.

**TWO IMPERMEABLE BARRIERS INTERSECTING AT RIGHT ANGLES**

The image-well system for a discharging well in an aquifer bounded on two sides by impermeable barriers that intersect at right angles is shown in figure 39. Although the drawdown effects of the primary image wells,  $I_1$  and  $I_2$ , combine in the desired manner with the effect



**NOTES:**

Image wells,  $I$ , are numbered in the sequence in which they were considered and located

Open circles signify discharging wells

FIGURE 39.—Plan of image-well system for a discharging well in an aquifer bounded by two impermeable barriers intersecting at right angles.

of the real well at their respective boundaries, each image well produces an unbalanced drawdown at the extension (reflection) of the other boundary. These unbalanced drawdowns at the boundaries produce a hydraulic gradient, with consequent flow across the extension of each boundary, and therefore do not completely satisfy the requirement of no flow across the boundaries of the real system. It is necessary, therefore, to use a secondary image well,  $I_3$ , which balances the residual effects of the two primary image wells at the two extensions of the boundaries. The image system is then hydraulically in complete accord with the physical boundary conditions. The problem thereby has been simplified to consideration of four discharging wells in an infinite aquifer.

**IMPERMEABLE BARRIER AND PERENNIAL STREAM INTERSECTING AT RIGHT ANGLES**

The image-well system for a discharging well in an aquifer bounded on two sides by an impermeable barrier and a perennial stream which intersect at right angles is shown in figure 40. The perennial stream of figure 40 might also represent a canal, drain, lake, sea, or any other line source of recharge sufficient to maintain a constant head at this boundary. As before, the drawdown effects of the primary images,  $I_1$  and  $I_2$ , combine in the desired manner with the effects of the real well at their respective boundaries. However, discharging image well  $I_1$  produces a drawdown at the extension of the line source, which is a no-drawdown boundary, and recharging image well  $I_2$  causes flow across the extension of the impermeable barrier, which is a no-flow boundary. By placing a secondary recharging image well,  $I_3$ , at the appropriate distance from the extension of each boundary, the system is balanced so that no flow occurs across the impermeable barrier and no drawdown occurs at the perennial stream. Thus again the problem has been simplified to consideration of an infinite aquifer in which there operate simultaneously two discharging and two recharging wells.

The simplest way to analyze any multiple-boundary problem is to consider each boundary separately and determine how best to meet the condition of no flow or no drawdown, as the case may be, at that boundary. After the positions of the primary image wells have been established, the boundary positions should be reexamined to see if the net drawdown effects of the primary image wells satisfy all stipulated conditions of no flow or no drawdown. For each primary image causing an unbalance at a boundary position, or extension thereof, it is necessary to place a secondary image well at the same distance from the boundary but on the opposite side, both wells occupying a common line perpendicular to the boundary. When the combined drawdown (or buildup) effects of all image wells are found to produce the desired effect at this boundary the same procedure is executed with



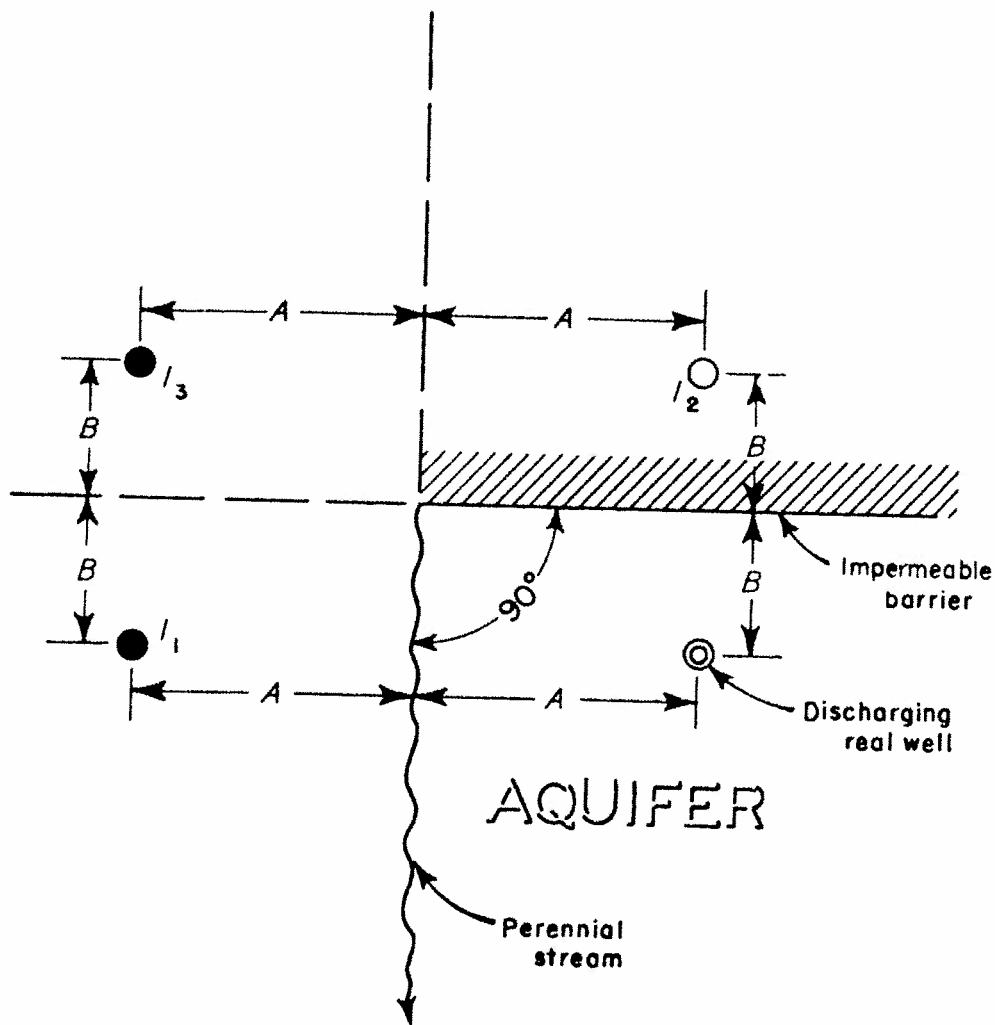

## NOTES:

Image wells,  $I$ , are numbered in the sequence in which they were considered and located

Open circles signify discharging wells

Filled circles signify recharging wells

FIGURE 40.—Plan of image-well system for a discharging well in an aquifer bounded by an impermeable barrier intersected at right angles by a perennial stream.

respect to the second boundary. Thus, the inspection and balancing process is repeated around the system until everything is in balance and all boundary conditions are satisfied, or until the effects of additional image wells are negligible compared to the total effect.

## TWO IMPERMEABLE BARRIERS INTERSECTING AT AN ANGLE OF 45°

Although it is intended here to consider the particular image-well system required for analyzing flow to a well in a 45-degree wedge-shaped aquifer, it is appropriate first to comment briefly on some general aspects of image-well systems in wedge-shaped aquifers. By analogy with similar heat-flow situations it is possible to analyze the flow to a well in a wedge-shaped aquifer, and equivalent image systems can be constructed regardless of the wedge angle involved. However, closed image systems that are the simplest to construct and analyze occur when the wedge angle,  $\theta$ , of the aquifer equals (or can be approximated as equal to) one of certain aliquot parts of 360°. These particular values of  $\theta$  may be specified as follows (after Walton, 1953, p. 17), keeping in mind that it is required to analyze flow to a single pumped well situated anywhere in the aquifer wedge: If the aquifer wedge boundaries are of like character,  $\theta$  must be an aliquot part of 180°. If the boundaries are not of like character,  $\theta$  must be an aliquot part of 90°.

Other simple solutions not covered by the above rule appear possible when  $\theta$  is an odd aliquot part of 360°, the pumped well is on the bisector of the wedge angle, and the boundaries are similar and impermeable. For any of the foregoing special situations it can be shown, with the aid of geometry, that the number of image wells,  $n$ , required in analyzing the flow toward the single real pumping well is given by the relation

$$n = \frac{360^\circ}{\theta} - 1. \quad (79)$$

It can also be shown that the locus of all image-well locations, for a given aquifer-wedge problem, is a circle whose center is at the wedge apex and whose radius equals the distance from the apex to the real discharging well (see figure 45).

The image-well system for a discharging well in a wedge-shaped aquifer bounded by two impermeable barriers intersecting at an angle of 45° is shown in figure 41. The real discharging well is reflected across each of the two boundaries which results in location of the two primary image wells  $I_1$  and  $I_2$  as shown. Considering boundary 1 only, the effects of the real well and image well  $I_1$ , are seen to combine so that, as desired, no flow occurs across that boundary. However, image well  $I_2$  will produce flow across boundary 1 unless image well  $I_3$  is added at the location shown. The system now satisfies the condition of no flow across boundary 1. Repeating this examination process for boundary 2 only, it is seen that the effects of the real well and image well  $I_2$  combine, as desired, to produce no flow across boundary 2. However, image wells  $I_1$  and  $I_2$  will produce flow

across this boundary unless image wells  $I_4$  and  $I_5$  are added as shown. The image system now satisfies the condition of no flow across boundary 2. Reexamining, it is seen that image wells  $I_4$  and  $I_5$  will produce flow across boundary 1 unless image wells  $I_6$  and  $I_7$  are added as shown. A final appraisal of the effects at boundary 2, shows that the entire system of image wells, plus the real well, satisfies the requirement of no flow across the boundary. Thus the flow field caused by a discharging well in this wedge-shaped aquifer can be simulated by a total of eight discharging wells in an infinite aquifer. The seven image wells have replaced the two barriers. The drawdown at any point between the two barriers can then be computed by adding the

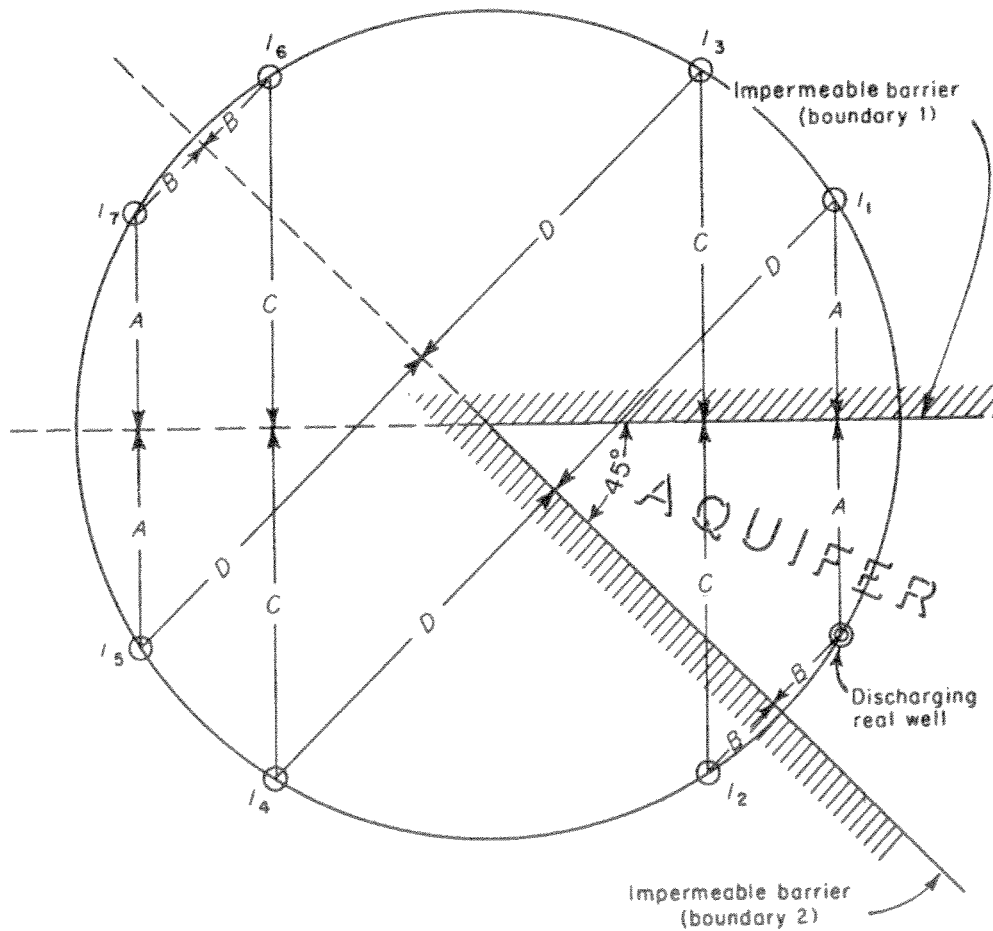

NOTES:

Image wells,  $I$ , are numbered in the sequence in which they were considered and located

Open circles signify discharging wells

FIGURE 41.—Plan of image-well system for a discharging well in an aquifer bounded by two impermeable barriers intersecting at an angle of  $45^\circ$ .

effects produced at that point by the real well and the seven image wells. Each image well begins discharging at the same rate and at the same time as the real well.

**IMPERMEABLE BARRIER PARALLEL TO A PERENNIAL STREAM**

Shown in figure 42 is the image-well system for a discharging well in an aquifer bounded by an impermeable barrier and cut by a fully penetrating perennial stream parallel to the barrier. A recharging image well,  $I_1$ , and a discharging image well,  $I_2$ , are placed as shown to satisfy respectively the conditions that no drawdown can occur along the line source, and no flow can occur across the impermeable barrier. Although these two primary image wells produce, in conjunction with the real well, the desired effects at their respective boundaries, each image well produces a residual effect at the opposite boundary which conflicts with the stipulated boundary conditions. It is therefore necessary to add a secondary set of image wells,  $I_3$  and  $I_4$ , as shown, to produce effects that will combine properly with the residual effects of the primary images. Each image well in the secondary set will again produce residual effects at the opposite boundary, and similarly with each successively added image pair there will be residual effects at the boundaries. It should be evident, however, that as more pairs of image wells are added the effects of adding a new pair have lesser influence on the cumulative effect at each boundary. In other words it is only necessary to add pairs of image wells until the residual effects associated with addition of the next pair can be considered to have negligible influence on the cumulative effect at each boundary. It is seen in figure 42 that there is a repeating pattern in the locations of the image wells. Therefore, after the positions of the first images have been determined, it is possible to locate by inspection as many more as are needed for the practical solution of the problem. Once the required number of image pairs has been determined, the aquifer boundaries can be ignored and the problem analyzed like any other multiple-well problem in an infinite aquifer.

If the two parallel boundaries are of like character—that is, if the perennial stream in figure 42 were replaced by an impermeable barrier or if the impermeable barrier were replaced by a perennial stream—the positions of the image wells would not be changed. In the first case, however, all the images would be discharging wells, and in the second case the image system would be an alternating series of recharging and discharging wells.

**TWO PARALLEL IMPERMEABLE BARRIERS INTERSECTED AT RIGHT ANGLES BY A THIRD IMPERMEABLE BARRIER**

The image-well system for a discharging well in this type of areally restricted aquifer is shown in figure 43. The positions of the images are determined as before by adding imaginary discharging wells so

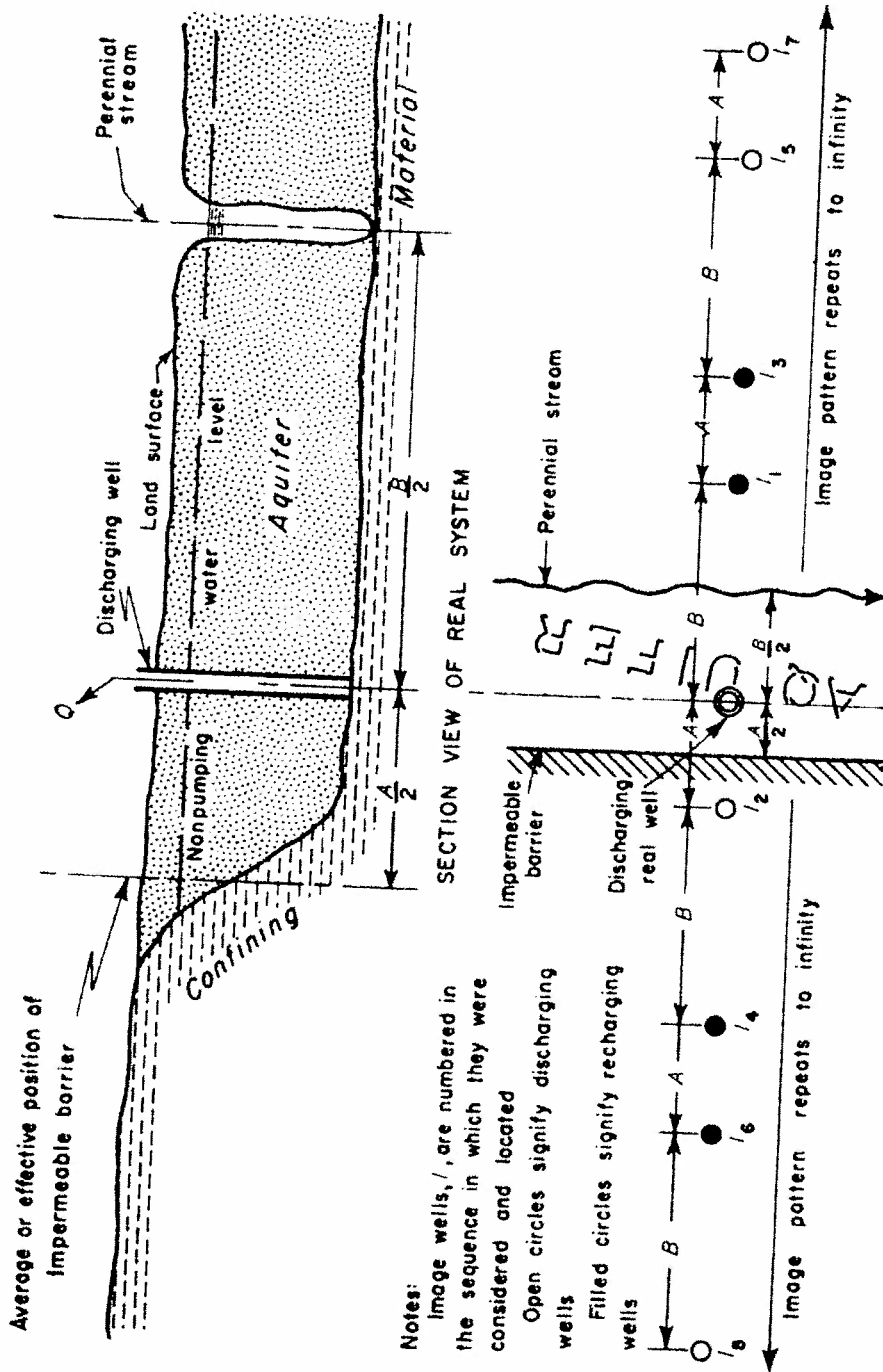
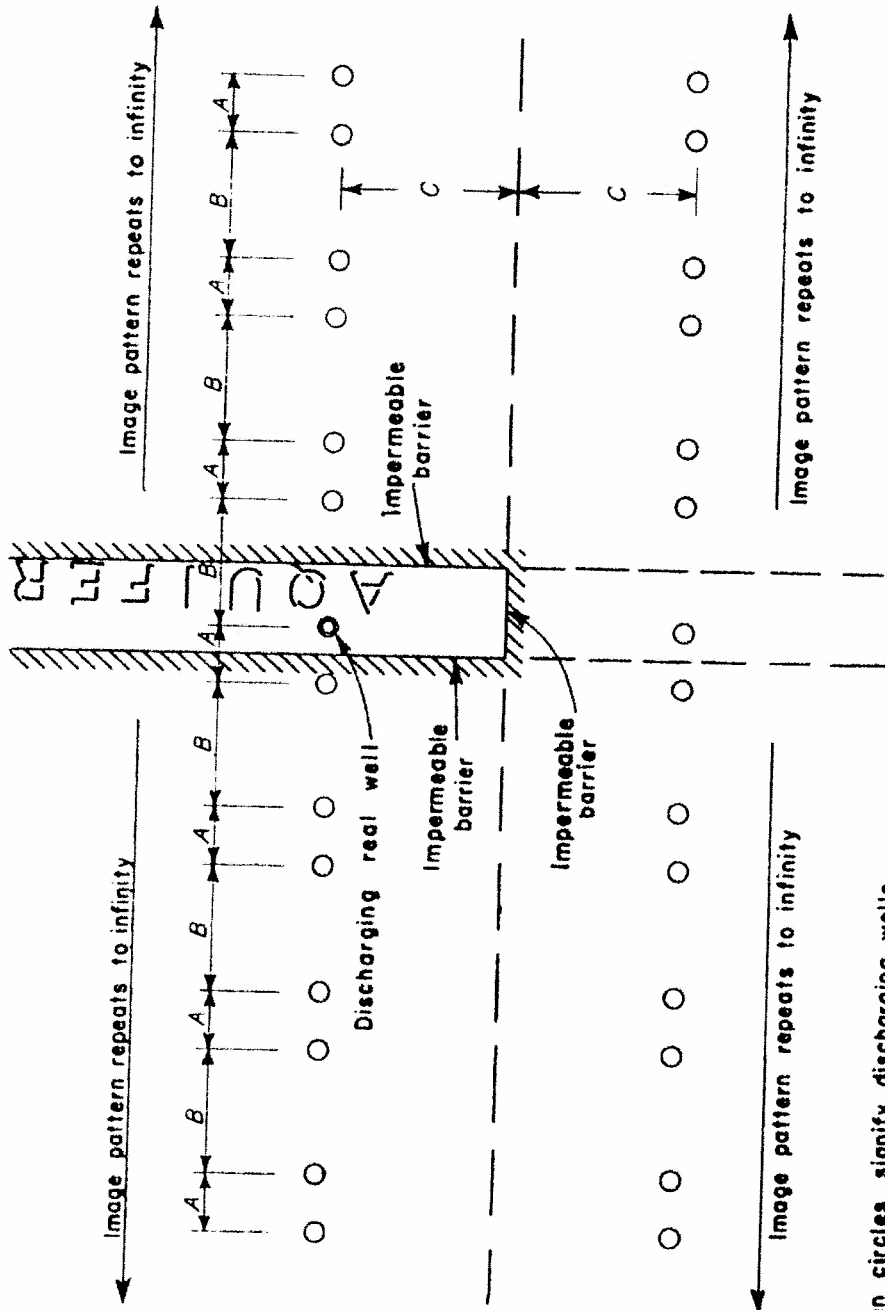

FIGURE 42.—Image-well system for a discharging well in an aquifer bounded by an impermeable barrier parallel to a perennial stream.



Note:

Open circles signify discharging wells

FIGURE 43.—Plan of image-well system for a discharging well in an aquifer bounded by two parallel impermeable barriers intersected at right angles by a third impermeable barrier.

that, in combination with the real discharging well, the condition of no ground-water flow across any of the three boundaries is established. As shown in the figure, two parallel lines of discharging image wells are required, separated by twice the distance between the real well and the barrier that intersects the two parallel barriers. Theoretically the two lines of image wells extend to infinity in both directions from the real well. The practical analysis of a problem of this kind, however, requires the addition of only enough images so that the effect of adding the next image, in any of the directions involved, has a negligible influence on the cumulative effect at each of the boundaries. It is seen from figure 43 that there is a repeating pattern in the positions of the image wells, so that the locations of only the first few images are required to determine the locations of as many succeeding image wells as are needed. For the case of two parallel impermeable barriers intersected at right angles by a perennial stream, the image system would be the same as shown by figure 43 except that all images on the line reflected across the stream would be recharging wells.

**RECTANGULAR AQUIFER BOUNDED BY TWO INTERSECTING IMPERMEABLE BARRIERS PARALLELING PERENNIAL STREAMS**

The image-well system for a discharging well in such an aquifer is shown by figure 44. The positions of the images are determined in the manner previously described. It is seen from figure 44 that there is again a repeating pattern that extends to infinity in all directions from the real well. Thus only the first few images need be located to determine the positions of as many succeeding images as are required in the practical solution of the problem. If the four boundaries in figure 44 were all impermeable barriers, all images would be discharging wells; and if the four boundaries were all perennial streams, the image system would be alternating series of recharging and discharging wells.

**APPLICABILITY OF IMAGE THEORY INVOLVING INFINITE SYSTEMS OF IMAGE WELLS**

Referring to the three problems discussed in the three preceding sections, it will be observed that in each situation the aquifer involved is limited in areal extent by two or more boundaries. Furthermore, the arrangement of the boundaries is such that at least two are parallel to each other, which means that analysis by the image theory requires use of an image-well system extending to infinity.

It has been stated, in discussing the practical aspects of using an infinite image-well system, that the individual effects of image wells need be added only out to the point where the effect associated with the addition of the next more distant well (or wells, depending on the symmetry of the array) can be considered to have negligible influence on the cumulative effect. Although this criterion ostensibly provides

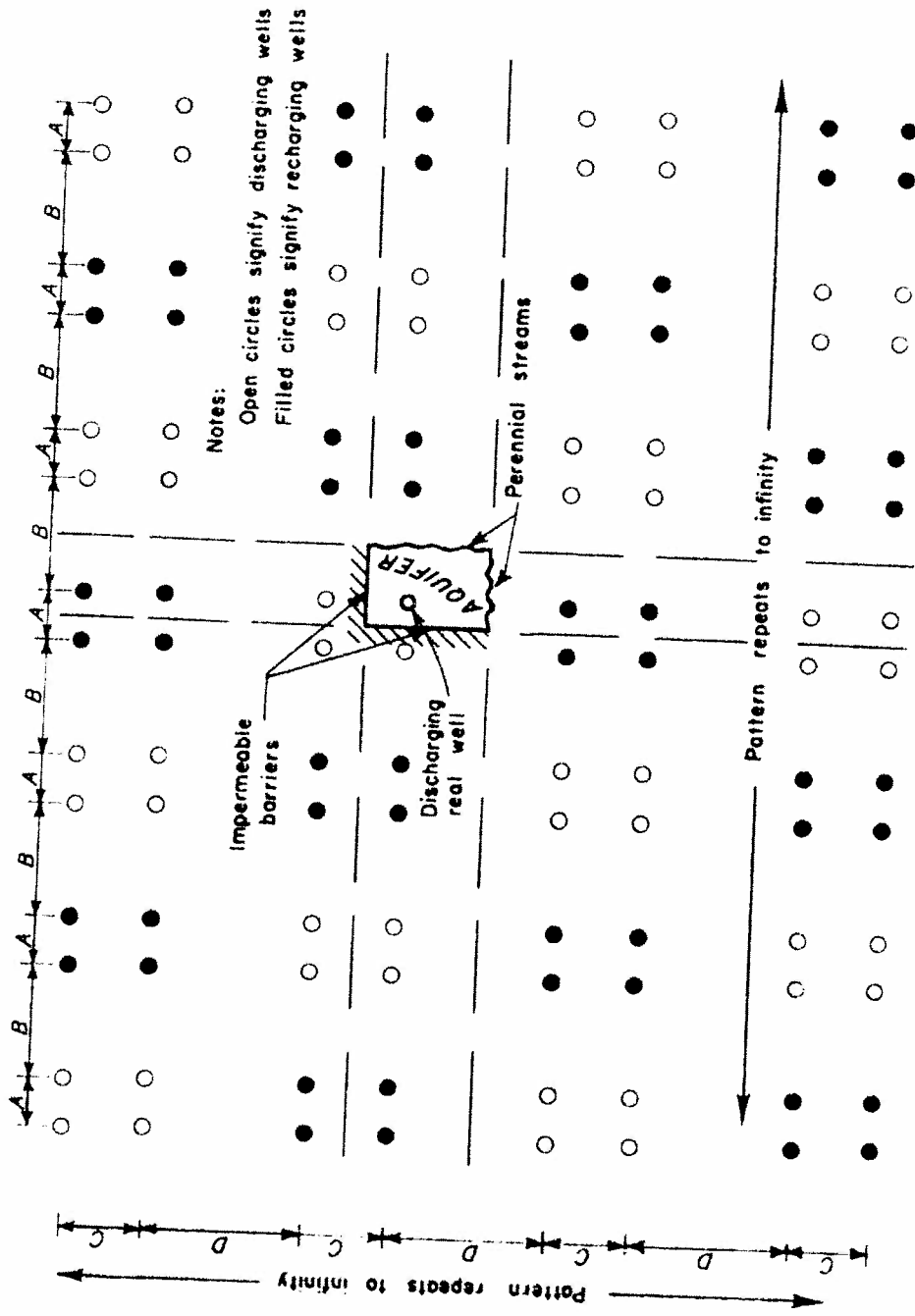

FIGURE 44.—Plan of image-well system for a discharging well in a rectangular aquifer enclosed by 2 intersecting impermeable barriers and 2 intersecting perennial streams.



a reliable and practical means of terminating what would otherwise be an endless analytical process, closer scrutiny appears warranted. There is no reason to state categorically that this practical approach to a solution should never be tried. Undoubtedly there will occur situations wherein sensible results can be obtained. On the other hand it seems prudent to observe that if the process of algebraically summing the individual effects of an infinite system of image wells is terminated anywhere short of infinity, there is no simple way of determining what proportion of the infinite summation is represented by the partial summation. Although addition of the next image well (or wells) might have a negligible influence on the sum of all image-well effects considered out to that point, there is no simple way of deciding whether the same may be said of the total influence represented by adding the effects of say the next 10 or 20 or 100 more distant image wells. Thus it would appear wise to keep in mind the possible limitations of any solution involving the use of an infinite system of image wells.

#### COROLLARY EQUATIONS FOR APPLICATION OF IMAGE THEORY

The nature and location of hydrologic boundaries of water-bearing formations in some cases can be determined from the analysis of pumping-test data. Considering the discussion in the preceding sections, it should be evident that in an aquifer whose extent is limited by one or more boundaries, a plot of drawdown or recovery data will depart from the form that would be expected if the aquifer were of infinite extent. Thus, in a problem involving a discharging well in a semi-infinite aquifer bounded by an impermeable barrier, some part of a time-drawdown plot may be steepened by the boundary effects. Conversely, if the boundary involved in the same type of problem were a perennial stream, a part of the time-drawdown plot may be flattened because of the boundary effects.

Imagine a pumping test made in an aquifer whose extent is limited by one or more boundaries. During the early part of the test, the drawdown data for observation wells close to the pumped well will reflect principally the pumping effects. As the test continues, however, there will very likely come a time for each observation well when the measured drawdowns reflect the net effect of the pumped well and any boundaries that are present. At distant observation wells boundary effects may arrive almost simultaneously with the effect of the real discharging well. Thus determination of the aquifer coefficients of transmissibility and storage should be based on the early drawdown data, as observed in a well near the pumped well, before the boundary effects complicate the analysis. Superposition and matching of a plot of these early data ( $s$  versus  $r^2/t$ ) on the Theis type curve permits

drawing in the type-curve trace. Extension or extrapolation of this trace beyond the early data indicates the trend the drawdowns would have taken if the pumping had occurred in an infinite aquifer. The departure,  $s_i$ , of the later observed data from this type-curve trace represents effects of the boundaries on the drawdown. The subscript  $i$  refers to the image-well system substituted as the hydraulic equivalent of the boundaries. Usually it is convenient to note values of  $s_i$  at a number of points along the data curve and to replot these departures versus values of  $r_i^2/t$  on the same graph sheet that was used in determining the coefficient of storage and transmissibility from the early data. The subscript  $r$  refers to the real discharging well. The latter part of the replotted departure data may again deviate from the type-curve trace if the cone of depression has intercepted a second boundary. As before, the departures can be replotted against corresponding values of  $r_i^2/t$  to form a second departure curve. This process should be repeated until the last departure curve shows no deviation from the type curve. The observed data array will then have been separated into its component parts which can be used to compute the distances between the observation wells and the image wells.

Inasmuch as the aquifer is assumed to be homogeneous (that is, the coefficients of transmissibility and storage are constant throughout the aquifer) it follows from equation 8 that

$$\frac{1.87S}{T} = \frac{u_r}{r_r^2/t} = \frac{u_i}{r_i^2/t} \quad (80)$$

where the subscripts  $r$  and  $i$  have the significance previously given. If on the plots of early drawdown data and first-departure curve a pair of points is selected so that the drawdown component caused by the real well,  $s_r$ , and the drawdown component caused by the image well,  $s_i$ , are equal, it follows that  $u_r = u_i$ . On the plots of observed early drawdowns and first departures just described,  $s_r$  and  $s_i$  obviously occur at different elapsed times, which can be labelled  $t_r$  and  $t_i$ , respectively. Equation 80 can therefore be rewritten as follows:

$$\frac{r_i^2}{t_i} = \frac{r_r^2}{t_r} \quad (81)$$

or

$$r_i = r_r \sqrt{\frac{t_i}{t_r}} \quad (82)$$

Equation 81, known as the "law of times" in the physics of heat conduction, shows that at a given observation well location the times of occurrence of equal drawdown components vary directly and only

as the squares of the distances from the observation well to the pumped well and to its image.

Referring to the data plots mentioned earlier in this section, note, for the pair of points selected, that values of  $s_r$  and  $r_r^2/t_r$  will be read from the early drawdown data while values of  $s_i$  and  $r_i^2/t_i$  will be read from the first departure curve. Equation 82 can be made more useful, therefore, if it is rewritten in the form

$$r_i = r_r \sqrt{\frac{r_r^2/t_r}{r_i^2/t_i}} \quad (83)$$

Equation 83 now affords a ready means of computing the distance from an observation well to an image well. Similar analysis may be made of each departure curve constructed from the original drawdown data.

Stallman (1952) has described a convenient method for computing  $r_i$  when the observed drawdown in the aquifer represents the algebraic sum of the drawdown effects from one real well and one image well. If equation 6 is used to provide expressions for  $s_r$  and  $s_i$ , and  $W(u)$  is substituted as a symbolic form of the exponential integral, it is seen that the drawdown at the observation well is

$$s = s_r \pm s_i = \frac{114.6Q}{T} [W(u)_r \pm W(u)_i] \quad (84)$$

From equation 80,

$$\frac{r_i}{r_r} = \sqrt{\frac{u_i}{u_r}}$$

or

$$r_i = r_r \sqrt{\frac{u_i}{u_r}} \quad (85)$$

From equations 84 and 85, it can be seen that  $r_i$  and the sum of the  $W(u)$  terms in equation 84 can be expressed in terms of  $r_r$  and the ratio  $u_i/u_r$ . Thus for any given values of  $\sqrt{u_i/u_r} = K$ , a type curve can be constructed by plotting assumed values of  $u_r$  against corresponding computed values of the bracketed portion of equation 84 [which may be written in abbreviated form as  $\sum_r W(u)$ ]. The data plot,  $s$  versus  $t$ , will match this constructed type of curve if the observation well is located so that the ratio  $r_i/r_r$  equals the given value of  $K$ . However, if a family of type curves is drawn for a number of given values of  $K$ , the observed data plot,  $s$  versus  $t$ , for any observation well, can be compared with the set of type curves. Once

the best matching curve is found, any convenient matchpoint is selected and the coordinate values,  $s$ ,  $t$ ,  $u_r$ ,  $\sum_{r,i} W(u)$ , and  $K$  are noted. These values, substituted in equations 80, 84, and 85 provide the means for computing  $T$ ,  $S$ , and  $r_i$ .

Stallman's set of curves is the familiar type-curve  $u$  versus  $W(u)$ , used in conjunction with the Theis formula, with a series of appendage curves (two for each value of  $K$ ) asymptotic to it. The trend of the appendage curve for a recharging image well is below, and for a discharging image above, the Theis curve. Appendage curves could have been constructed by assuming values of  $u_i$  instead of  $u_r$ . In this event, however, the matching process would not be as direct inasmuch as the parent type curve, instead of occupying a single position, would shift along the  $u$  axis with each pair of appendage ( $K$ ) curves.

The appendage curves, computed by Stallman, are for ideal image wells—those which are pumped or recharged at the same rate as the real well. The hydrogeologic structure which gives rise to the hypothetical image is not always ideal; therefore the hypothetical images are not always ideal. For this case the method of plotting departures may yield an erroneous and misleading analysis. On the other hand, the deviations from ideality can be seen immediately if the observed data plot  $s$  versus  $t$  is matched to Stallman's set of type curves. Furthermore, for nonideal images, the most accurate selection of  $K$  is made by utilizing the portion of the appendage curve that is nearest the parent or Theis type curve.

If little is known of the possible location of a local hydraulic boundary a minimum of three observation wells is required to fix the position of an image well, which in turn permits location of the boundary. After the distances from the individual observation wells to the image well have been computed, arcs are scribed with their centers at the observation wells and their radii equal to the respective computed distances to the image well. The intersection of the arcs at a common point fixes the location of the image well, and the strike of the boundary is represented by the perpendicular bisector of a line connecting the pumped well and the image well.

Another graphical method for locating a hydraulic boundary in the vicinity of a discharging well was devised by E. A. Moulder (1951, written communication, p. 61). The geometry is shown in figure 45. A circle is scribed whose center is at a nearby observation well,  $O$ , and whose radius,  $r_i$ , is equal to the computed distance from the observation well to the image well. The image well lies somewhere on this circle, say, at point  $I$ . Lines are drawn from the selected point  $I$  to the observation well and to the real discharging well,  $P$ . If point  $I$  is the image-well location and if  $A$  is the midpoint of the

line  $IP$ , then point  $A$  lies on the boundary. It can be proved by geometry, that the locus of all points  $A$  determined in this manner is a circle, of radius  $BA$  or  $r_w/2$ , with its center,  $B$ , located midway between the discharging well and the observation well. Moulder's method is particularly useful in aquifer-test situations where data from only one or two observation wells are available for locating a boundary position. If the approximate position of a suspected boundary is known before a pumping test begins, it is desirable to locate most of the observation wells along a line parallel with the boundary and passing through the pumped well. If feasible the range of distances from the observation wells to the pumped well should be distributed logarithmically to assure well-defined arc intersections in the graphics of locating a point on that boundary. At least one observation well

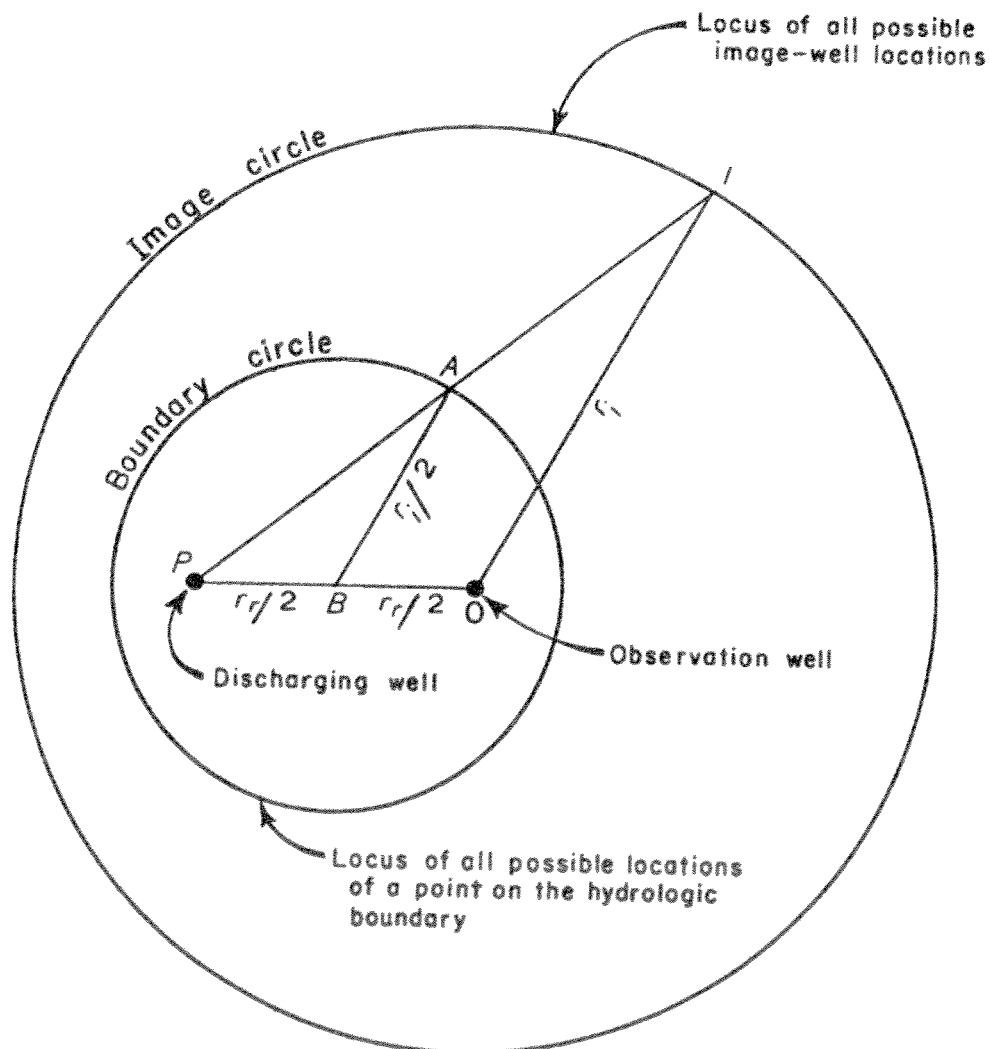

FIGURE 45.—Geometry for locating a point on a hydrologic boundary, with reference to the locations of a discharging well and a nearby observation well.

should be located close enough to the pumped well so that the early drawdown data, unaffected by the boundary, can be used in computing the aquifer coefficients of storage and transmissibility.

#### APPLICABILITY OF ANALYTICAL EQUATIONS

The assumptions used in developing the equations presented in this report include the stipulation that the aquifer is homogeneous and isotropic. Even though most naturally deposited sediments do not satisfy this condition, the equations may still be applied and the results qualified according to the extent of nonhomogeneity. It should be realized that homogeneity is a relative term with respect to time and space. As an illustration, consider an aquifer composed of two types of material—a fine sand and a very coarse sand. Assume that these materials occur individually in deposits having the shape of cubes one-eighth of a mile on a side, and that alternate rows of cubes (squares in plan view) are offset a distance equal to one-half the length of one side of the cube (that is, one-sixteenth of a mile). Let the fine and coarse sand occur in alternate cubes along the continuous rows, and assume that water occurs, in the aquifer thus created, under water-table conditions. Strictly speaking, this aquifer, of infinite extent, would now be described as nonhomogeneous. However, the areal extent of the portion of the aquifer sampled in a test would be significant in judging this element of the aquifer's description. For example, if a discharging well test is conducted in the center of one of the squares and if the test is terminated before the area of influence reaches the perimeter of the square, the test results probably would be considered excellent and the aquifer described as homogeneous. The results would in no way differ from the results to be expected if a similar test were made on an infinite "homogeneous" aquifer, composed of material identical to that occurring in the limited area here tested.

As another example, again consider an aquifer test using a discharging well in the center of one of the squares of the hypothetical aquifer. The nearest of several observation wells is at a radius of 5 miles from the pumped well, and the test is run until the area of influence is described by a circle 10 miles in radius. Coefficients of transmissibility computed from data collected at all the observation wells should be in close agreement (although not equal to the values obtained from the previously described test), and again the hypothetical aquifer, even on the larger scale represented in this sample, would be adjudged homogeneous. This judgment relies upon the reasoning that, for the distances involved, the slightly meandering path of water, as it moves toward the well, may be described statistically as conforming to the concept of radial flow. For any case in which nonhomogeneity is so

distributed that the flow field statistically fits the geometry of the mathematical model, the mathematical solution will provide a sound analysis. Conversely, when the flow field or a portion thereof is significantly distorted in the area of observation, the assumption of homogeneity is incorrect. Thus, for the hypothetical aquifer considered in the two preceding examples, the distorted condition is seen to exist if the area of influence of the discharging well were to extend to a radius of about  $\frac{1}{4}$  to 1 mile—that is, a little beyond the limits of one cube of the aquifer material.

Often the field situation is encountered where a zone of relatively impermeable material such as a clay lens, of limited thickness and extent, occurs in an aquifer. It should be evident from the foregoing examples and discussion, however, that the presence of this clay lens in the flow field will have less influence on aquifer test results when the effects of the test encompass an area of large radius than when the area affected is of small radius.

An important criterion, therefore, regarding the applicability of the equations discussed in this report, is the amount the flow field is distorted, as compared with the flow field that would have been observed in an ideal aquifer.

It should be understood that the numerical results obtained by substituting aquifer-test data in an appropriate mathematical model indicate the transmissibility and storage coefficients for an ideal aquifer. The hydrologist must judge how closely the real aquifer resembles this particular ideal. It is usually recognized, for example, that in short pumping tests under water-table conditions the water does not drain from the smaller openings in the unwatered portion of the aquifer in a manner even approximating the instantaneous release assumed in devising the mathematical model. Similarly, in testing artesian aquifers it is recognized that the aquifer skeleton does not adjust instantaneously to the change in head, that considerable water is often contributed by intercalated clay beds, and furthermore that water leaks through the confining beds, which in the mathematical model have been assumed to be impermeable. However, these recognized departures from the ideal do not constitute grounds for abandoning, or rarely using, available analytical equations. Such departures simply add emphasis to the admonition that mere substitution of aquifer-test data in an equation will not of itself assure anyone of establishing the correct hydraulic properties for that aquifer. The mechanics of applying any of the analytical equations in this report must be accomplished with sound professional judgment, followed by critical evaluation and testing of the results.



## REFERENCES

- Andreasen, G. E., and Brookhart, J. W., Reverse water-level fluctuations: U.S. Geol. Survey open-file rept.
- Barksdale, H. C., Sundstrom, R. W., and Brunstein, M. S., 1936, Supplementary report on the ground-water supplies of the Atlantic City region: New Jersey State Water Policy Comm. Spec. Rept. 6, p. 87-91.
- Bennett, R. R., and Meyer, R. R., 1952, Geology and ground-water resources of the Baltimore area: Maryland Dept. Geology, Mines and Water Resources Bull. 4, p. 54-58.
- Brown, R. H., and Ayer, G. R., 1948, Upstate New York, in Paulsen, C. G., and others, Water levels and artesian pressure in observation wells in the United States in 1945: U.S. Geol. Survey Water-Supply Paper 1023, Part 1, North-eastern States, p. 193-195.
- Byerly, Perry, 1933, Analysis of seismograms of near earthquakes, chap. 16 in Seismology: Natl. Research Council Bull. 90, Physics of the Earth, v. 6.
- Casagrande, Arthur, 1937, Seepage through dams: Harvard Graduate School Eng. Pub. 209.
- Darcy, Henry, 1856, Les Fontaines publiques de la ville de Dijon (The water supply of Dijon): Paris, Victor Dalmont, 647 p.
- Dupuit, Jules (Jules), 1848, Études théoriques et pratiques sur le mouvement des eaux courantes [Theoretical and practical studies on the movement of running water]: Paris, Carilian-Goeury et V. Dalmont, 275 p.
- Ferris, J. G., 1950, Quantitative method for determining ground-water characteristics for drainage design: Agr. Engineering, v. 31, no. 6, p. 285-291.
- 1951, Cyclic fluctuations of water level as a basis for determining aquifer transmissibility: Internat. Union Geodesy and Geophysics, Assoc. Sol. Hydrology Assemb., Brussels, 1951, v. 2, p. 148-155; dupl. as U.S. Geol. Survey Ground Water Note 1, 1952.
- Ferris, J. G., and Knowles, D. B., 1954, Slug test for estimating transmissibility: U.S. Geol. Survey Ground Water Note 26.
- Forchheimer, Philipp, 1901, Wasserbewegung durch Boden (Ground-water motion): Ver. Deutscher Ing. Zeitschr., [Berlin], v. 45, p. 1736-1741, 1781-1788.
- 1930, Hydraulik: 3d ed., Leipzig and Berlin, Teubner.
- Gray, Andrew, Mathews, C. B., and MacRobert, T. M., 1931, Treatise on Bessel functions and their applications to physics: London, Macmillan Co., Ltd.
- Glee, G. J. de, 1930, Over grondwaterstromingen bij wateronttrekking door middel van putten [On ground-water currents through draining by means of wells]: Delft [Netherlands] Tech. Hogeschool Thesis.
- Hagen, G. H. L., 1839, Ueber die Bewegung des Wassers in engen cylindrischen Rohren [Movement of water in a narrow cylindrical tube]: Annalen Physik u. Chemie [Leipzig], v. 46, p. 423-442.
- Hantush, M. S., 1955, Preliminary quantitative study of the Roswell ground-water reservoir, New Mexico: Socorro, New Mexico Inst. Mining and Technology, 113 p.
- Hantush, M. S., and Jacob, C. E., 1955, Non-steady radial flow in an infinite leaky aquifer: Am. Geophys. Union Trans., v. 36, no. 1, p. 95-100.
- Ingersoll, L. R., Zobel, O. J., and Ingersoll, A. C., 1948, Heat conduction: New York, McGraw-Hill Book Co.
- Israelsen, O. W., 1950, Irrigation principles and practices: 2d ed., New York, John Wiley & Sons.



- Jacob, C. E., 1939, Fluctuations in artesian pressure produced by passing railroad trains as shown in a well on Long Island, New York: *Am. Geophys. Union Trans.*, Pt. 4, p. 666-674, August; dupl. as U.S. Geol. Survey Ground Water Note 16, 1953.
- 1940, On the flow of water in an elastic artesian aquifer: *Am. Geophys. Union Trans.*, pt. 2, p. 574-586, July; dupl. as U.S. Geol. Survey Ground Water Note 8, 1953.
- 1941, Notes on the elasticity of the Lloyd sand on Long Island, New York: *Am. Geophys. Union Trans.*, pt. 3, p. 783-787, August; dupl. as U.S. Geol. Survey Ground Water Note 8, 1953.
- 1943, Correlation of ground-water levels and precipitation on Long Island, New York: *Am. Geophys. Union Trans.*, pt. 2, p. 564-573 [Jan. 1944]; also, as New York State Water Power and Control Comm. Bull. GW 14, 1945.
- 1944, Notes on determining permeability by pumping tests under water-table conditions: U.S. Geol. Survey open-file rept.
- 1945, Partial penetration of pumping well, adjustments for: U.S. Geol. Survey open-file rept.
- 1946, Radial flow in a leaky artesian aquifer: *Am. Geophys. Union Trans.*, v. 27, no. 2, p. 198-205; dupl. as U.S. Geol. Survey Ground Water Note 13, 1953.
- 1950, Flow of ground water, chap. 5 in Rouse, Hunter, *Engineering hydraulics*: New York, John Wiley & Sons.
- Jacob, C. E., and Lohman, S. W., 1952, Nonsteady flow to a well of constant drawdown in an extensive aquifer: *Am. Geophys. Union Trans.*, v. 33, no. 4, p. 559-569.
- Klonne, F. W., 1880, Die periodischen Schwankungen in den inundirten Kohlen-schächten von Dux [The periodical fluctuations in the flooded coal shafts of Dux]: *Akad. Wiss. Wien Sitzungsber.*, v. 81, p. 101, Wien.
- Krul, W. F. J. M., and Lieftrinck, F. A., 1946, Present ground-water investigations in the Netherlands: New York and Amsterdam, Elsevier Pub. Co.
- LaRocque, G. A., Jr., 1941, Fluctuations of water level in wells in the Los Angeles basin, California, during five strong earthquakes, 1933-1940: *Am. Geophys. Union Trans.*, pt. 2, p. 374-386.
- Leggette, R. M., and Taylor, G. H., 1935, Earthquakes instrumentally recorded in artesian wells: *Seismol. Soc. America Bull.*, v. 25, p. 169-175.
- Lohman, S. W., 1957, Method of determining the coefficient of storage from straight-line plots without extrapolation: U.S. Geol. Survey Ground Water Note 33.
- Meinzer, O. E., and Fishel, V. C., 1934, Tests of permeability with low hydraulic gradients: *Am. Geophys. Union Trans.*, v. 15, pt. 2, p. 405-409, June.
- Meinzer, O. E., and Hard, H. A., 1925, Artesian-water supply of the Dakota sandstone in North Dakota, with special reference to the Edgeley quadrangle: U.S. Geol. Survey Water-Supply Paper 520-E, p. 73-95, pls. 6-7.
- Milne, W. E., 1953, Numerical solution of differential equations: New York, John Wiley & Sons.
- Parker, G. G., and Stringfield, V. T., 1950, Effects of earthquakes, trains, tides, winds, and atmospheric pressure changes on water in the geologic formations of southern Florida: *Econ. Geology*, v. 45, no. 5, p. 441-460.
- Piper, A. M., 1933, Fluctuations of water surface in observation wells and at stream-gaging stations in the Mokelumne area, California, during the earthquake of December 20, 1932: *Am. Geophys. Union Trans.*, v. 14, p. 471-475.

- Poiseuille, J. L. M., 1846, Experimental investigations on the flow of liquids in tubes of very small diameter: Acad. Royal sci. et Inst. France, Math. Phys. Sci. Mem., v. 9, p. 433-543. (Translated by W. H. Herschel in Rheolog. Mem., v. 1, no. 1, 101 p., Easton, Pa., Jan. 1940.)
- Robinson, T. W., 1939, Earth tides shown by fluctuations of water levels in wells in New Mexico and Iowa: Am. Geophys. Union Trans., pt. 4, p. 656-666.
- Rouse, Hunter, ed., 1950, Engineering hydraulics: New York, John Wiley & Sons.
- Scarborough, J. B., 1950, Numerical mathematical analysis: 2d ed., Baltimore, Johns Hopkins Press.
- Shaw, F. S., 1953, Introduction to relaxation methods: New York, Dover Pub., Inc.
- Skibitzke, H. E., 1958, An equation for potential distribution about a well being bailed: U.S. Geol. Survey Ground Water Note 35.
- Slichter, C. S., 1899, Theoretical investigation of the motion of ground waters: U.S. Geol. Survey 19th Ann. Rept.; U.S. Geol. Survey Ground Water Note 22, 1954.
- Southwell, R. V., 1940, Relaxation methods in engineering science: London, Oxford Univ. Press.
- 1946, Relaxation methods in theoretical physics: London, Oxford Univ. Press.
- Stallman, R. W., 1952, Nonequilibrium type curves modified for two-well systems: U.S. Geol. Survey Ground Water Note 3.
- 1956, Numerical analysis of regional water levels to define aquifer hydrology: Am. Geophys. Union Trans., v. 37, no. 4, p. 451-460.
- Stearns, H. T., 1928, Record of earthquake made by automatic recorders on wells in California: Seismol. Soc. America Bull., v. 18, p. 9-15.
- Stearns, N. D., 1928, Laboratory tests on physical properties of water-bearing materials: U.S. Geol. Survey Water-Supply Paper 596-F, p. 121-176, pls 11-13.
- Steggewentz, J. H., and Van Nes, B. A., 1939, Calculating the yield of a well, taking account of replenishment of the ground water from above: Water and Water Eng. [London], v. 41, no. 517, p. 561-563.
- Taylor, D. W., 1948, Fundamentals of soil mechanics: New York, John Wiley & Sons, p. 156-198.
- Theis, C. V., 1935, Relation between the lowering of the piezometric surface and the rate and duration of discharge of a well using ground-water storage: Am. Geophys. Union Trans., pt. 2, p. 519-524; dupl. as U.S. Geol. Survey Ground Water Note 5, 1952.
- 1939, Earth tides expressed fluctuations of water level in artesian wells in New Mexico: U.S. Geol. Survey open-file rept.
- Theis, C. V., and Brown, R. H., 1954, Drawdown in wells responding to cyclic pumping: U.S. Geol. Survey Ground Water Note 23.
- Thiem, Gunther, 1906, Hydrologische methoden (Hydrologic methods): Leipzig, J. M. Gebhardt, 56 p.
- Turneaure, F. E., and Russell, H. L., 1901, Public water supplies: New York, John Wiley & Sons.
- U.S. National Bureau of Standards, 1952, Tables of the Bessel functions  $Y_0(x)$ ,  $Y_1(x)$ ,  $K_0(x)$ ,  $K_1(x)$ ,  $0 \leq x \leq 1$ : U.S. Natl. Bur. Standards Appl. Math Ser. 25, Sept. 11.
- 1954, Table of the error function and its derivative: U.S. Natl. Bur. Standards Appl. Math. Ser. 41, Oct. 22.

- Veatch, A. C., 1906, Fluctuations of the water level in wells, with special reference to Long Island, New York: U.S. Geol. Survey Water-Supply Paper 155, 83 p.
- Vorhis, R. C., 1953, Milwaukee "hydroseismograms" and their interpretation: U.S. Geol. Survey open-file rept.
- Walton, W. C., 1953, Hydraulic properties of a dolomite aquifer underlying the village of Ada, Ohio: Ohio Dept. Nat. Resources, Div. Water Tech. Rept. 1.
- Warren, M. A., 1952, Graphical short cuts in applying the nonequilibrium formula to ground-water problems: U.S. Geol. Survey open-file rept.
- Wenzel, L. K., 1942, Methods for determining permeability of water-bearing materials, with special reference to discharging-well methods, *with a section on Direct laboratory methods and bibliography on permeability and laminar flow*, by V. C. Fishel: U.S. Geol. Survey Water-Supply Paper 887, 192 p.
- Wenzel, L. K., and Sand, H. H., 1942, Water supply of the Dakota sandstone in the Ellendale-Jamestown area, North Dakota, with reference to changes between 1923 and 1938: U.S. Geol. Survey Water-Supply Paper 889-A.
- Werner, P. W., and Noren, Daniel, 1951, Progressive waves in non-artesian aquifers: *Am. Geophys. Union Trans.*, v. 32, no. 2, p. 238-244.
- Wyckoff, R. D., Botset, H. G., and Muskat, M., 1932, Flow of liquids through porous media under the action of gravity: *Physics*, v. 3, no. 2, p. 90-113.
- Young, Andrew, 1913, Tidal phenomena at inland boreholes near Cradock: *Royal Soc. South Africa Trans.*, v. 3, pt. 1, p. 61-105.